



OWNER'S MANUAL

Model Number

700374-2

700378-2

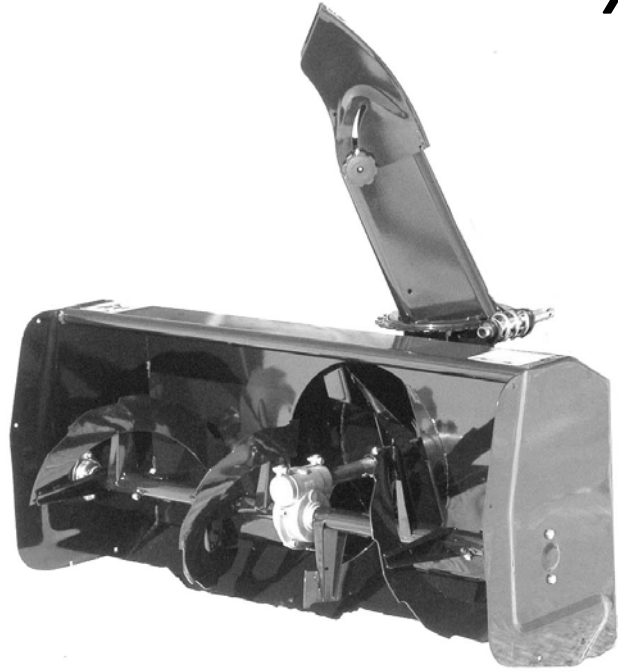

Berco

Northeast Two Stage 44" & 48" Snowblower

for

LAWN, YARD & GARDEN TRACTORS

* ASSEMBLY

* REPAIR PARTS

* OPERATION

* MAINTENANCE

CAUTION:

**READ & FOLLOW ALL SAFETY RULES & INSTRUCTIONS BEFORE
OPERATING YOUR EQUIPMENT**



LIMITED WARRANTY

Conditions and Products Covered:

BERCOMAC guarantees any part of the product or accessory manufactured by BERCOMAC and found in the reasonable judgment of BERCOMAC to be defective in material and or workmanship will be repaired or replaced by an authorized dealer without charge up to our maximum labor rates and pre-established times. For replacement parts only standard ground freight services are covered. This warranty extends to the original retail purchaser only and is not transferable to any subsequent purchasers.

Warranty Period

(from date of the original retail purchase)

- Residential use: 1 year
- Semi-commercial, professional or rental use: 90 days

Exceptions Noted Below; the following items are guaranteed by the original manufacturer and have their own warranty, conditions and limited time:

- Tire Chains: 90 days
- Engines: Will vary as per the manufacturer
Please refer to the engine manufacturer's warranty statement included with the unit. BERCOMAC is not authorized to handle warranty adjustments on engines.

Items and Conditions NOT Covered:

This warranty does not cover the following:

- Pick-up or delivery charges or in-home services fees.
- Any damage or deterioration of the unit, parts and or finish of these due to normal use, wear and tear, or exposure.
- Cost of regular use or maintenance service or parts, such as gas, oil, lubricants, tune-up parts, and adjustments.
- Any part or accessory which has been altered, modified, misused, neglected, accidentally damaged or not properly installed, maintained, stored or repaired not in accordance with the instructions in the owner's manual.
- Repair due to normal wear and or any wear items such as shear pins, bolts, belts, etc.
- Expedited freight fee services for replacement parts.
- Shear bolts and shear pins are to be considered as a preventive measure not as an assured protection, any damages resulting from the lack of shear bolts breakage are not covered.

NOTE: All warranty work must be performed by an authorized dealer using original (manufacturer) replacement parts.

NOTE: Bercomac reserves the right to change or improve the design of any part or accessory without assuming any obligation to modify any product previously manufactured.

Instructions for Obtaining Warranty Services:

Contact dealer where equipment was purchased or any other BERCOMAC service dealer to arrange service at their dealership. To locate a dealer convenient to you, access our website at www.bercomac.com. Don't forget to bring the product and your proof of purchase (sales receipt) to the BERCOMAC dealer.

Owner's Responsibilities:

BERCOMAC's defective equipment or part must be returned to an authorized dealer within the warranty period for repairs. In the event that defective merchandise must be returned to manufacturer for repairs, freight fees are prepaid and a written authorization from BERCOMAC must be obtained by dealer prior to the shipment. This warranty extends only to equipment operated under normal conditions. To validate a warranty claim, it is the user's responsibility to maintain and service the unit as specified in the owner's manual or to have the unit serviced at their dealer at their expense.

General Conditions:

The sole liability of BERCOMAC with respect to this warranty shall be strictly and exclusively repair and replacement as mentioned herein. BERCOMAC shall not have any liability for any other costs, loss or damage, including but not limited to, any incidental or consequential loss or damage.

In particular, without being limited to, BERCOMAC shall have no liability or responsibility for:

- Travel time, overtime, after hours time or other extraordinary repair charges or relating to repairs and or replacements outside of normal business hours.
- Rental of like or similar replacement equipment during the period of any, repair or replacement work.
- Any communicating or travel charges.
- Loss or damage to person or property other than that covered by the terms of this warranty.
- Any claims for lost revenue, lost profit or any similar costs as a result of damage or repair.
- Attorney's fees.

BERCOMAC's responsibility in respect to claims is limited to making the required repairs or replacement without charge up to our maximum labor rates and pre-established times and no claim of breach of warranty shall be cause for cancellation or rescission of the contract of sale of any product or accessory.

This warranty gives you specific legal rights. You may also have other rights, which vary from state to state.

TABLE OF CONTENTS

	Page
INTRODUCTION	2
SAFETY PRECAUTIONS	3
SAFETY DECALS	5
ASSEMBLY	
Tools required	6
Step 1: Snowblower Preparation	6
Step 2: Snowblower Installation	7
OPERATION	
Snowblower Operation	9
Controls	9
Snow Removal	9
MAINTENANCE	
Maintenance	10
Adjustments	10
Lubrication	10
Cleaning a Clogged Discharge Chute	10
Cutting Edge Maintenance	10
Auger and Fan Shear Bolt Replacement	10
End of Season Storage	10
Belt Installation, Adjustment and Replacement	11
DISMOUNTING	
Snowblower Dismounting	13
TROUBLESHOOTING	14
PARTS BREAKDOWN & LISTS	
Chute	16
Snowblower	18
TORQUE SPECIFICATION TABLE	22
OPTIONS & ATTACHMENTS	23

INTRODUCTION

TO THE PURCHASER

This new accessory was carefully designed to give years of dependable service. This manual has been provided to assist in the safe operation and servicing of your attachment.

NOTE: All photographs and illustrations in the manual may not necessarily depict the actual models or attachment, but are intended for reference only and are based on the latest product information available at the time of publication.

Familiarize yourself fully with the safety recommendations and operating procedures before putting the machine to use. Carefully read, understand and follow these recommendations and insist that they be followed by those who will use this attachment.



THIS SAFETY ALERT SYMBOL IDENTIFIES AN IMPORTANT SAFETY MESSAGE IN THIS MANUAL THAT HELPS YOU AND OTHERS AVOID PERSONAL INJURY OR EVEN DEATH. DANGER, WARNING, AND CAUTION ARE SIGNAL WORDS USED TO IDENTIFY THE LEVEL OF HAZARD. HOWEVER, REGARDLESS OF THE HAZARD, BE EXTREMELY CAREFUL.

DANGER: Signals an extreme hazard that will cause serious injury or death if recommended precautions are not followed.

WARNING: Signals a hazard that may cause serious injury or death if the recommended precautions are not followed.

CAUTION: Signals a hazard that may cause minor or moderate injury if the recommended precautions are not followed.

Record your attachment serial number and purchase date in the section reserved below (there is no serial number on the subframe). Your dealer requires this information to give you prompt, efficient service when ordering replacement parts. Use only genuine parts when replacements are required.

If warranty repairs are required please present this registration booklet and original sales invoice to your selling dealer for warranty service.

This manual should be kept for future reference.

Please check if you have received all the parts for your kit with the list of the bag and the list of the box.

SERIAL NUMBER : _____
(IF APPLICABLE)

MODEL NUMBER: _____

PURCHASE DATE : _____



SAFETY PRECAUTIONS



Careful operation is your best insurance against an accident. Read this section carefully before operating the vehicle and accessory. This accessory is capable of amputating hands and feet and throwing objects. Failure to observe the following safety instructions could result in serious injury. All operators, no matter how experienced they may be, should read this and other manuals related to the vehicle and accessory before operating. It is the owner's legal obligation to instruct all operators in safe operation of the accessory.

GLOSSARY:

In this manual, right and left sides are determined by sitting on the seat of the vehicle facing forward.

In this manual, "accessories" means attachments (snowblower, rotary broom, blade etc.) that you install on the vehicle (lawn tractors, A.T.V. s etc).

TRAINING:



This symbol, "Safety Alert Symbol", is used throughout this manual and on the accessory's safety labels to warn of the possibility of serious injury. Please take special care in reading and understanding the safety precautions before operating the vehicle and accessory.

1. Read this owner's manual carefully. Be thoroughly familiar with the controls and proper use of the vehicle and accessory. Know how to stop the unit and disengage the controls quickly.
2. Never allow children to operate the vehicle nor the accessory. Never allow adults to operate the vehicle nor the accessory without proper instructions.
3. No one should operate the vehicle nor the accessory while intoxicated or while taking medication that impairs the senses or reactions.
4. Keep the area of operation clear of all people, particularly small children and pets.

PREPARATION:

1. Thoroughly inspect the area where the accessory is to be used and remove door mats, all foreign objects and the like.
2. For motorized accessories, disengage all clutches and shift into neutral before starting engine.
3. Do not operate the accessory without wearing adequate winter outer garments. Avoid loose fitting clothing that can get caught in moving parts. Wear footwear that will improve footing on slippery surfaces.

4. Handle fuel with care, it is highly flammable.

- a) Use approved fuel container.
 - b) Never add fuel to a running engine or hot engine.
 - c) Fill fuel tank outdoors with extreme care. Never fill fuel tank indoors.
 - d) Never fill containers inside a vehicle, or on a truck or a trailer bed with a plastic liner. Always place containers on the ground, away from your vehicle, before filling.
 - e) When practical, remove gas-powered equipment from the truck or trailer and refuel it on the ground. If this is not possible, then refuel such equipment on a trailer with a portable container, rather than from a gasoline dispenser nozzle.
 - f) Keep the nozzle in contact with the rim of the fuel tank or container opening at all times, until refueling is complete. Do not use a nozzle lock-open device.
 - g) Replace fuel cap securely and wipe up spilled fuel.
 - h) If fuel is spilled on clothing, change clothing immediately.
5. Never attempt to make any adjustments while the engine (motor) is running (except when specifically recommended by manufacturer).
 6. Let the vehicle and accessory adjust to outdoor temperatures before using.
 7. Never use an accessory without proper guards, plates, or other safety protective devices in place
 8. Always make sure to wear the appropriate safety equipment required (glasses, muffs, mask...) for each type of product. See operation section.
 9. Always make sure of having safe traction on the vehicle by using the recommended accessories (chains, A.T.V. tracks, counterweights...). See operation section.
 10. **Never modify the accessory or any part without the written consent from the manufacturer.**



SAFETY PRECAUTIONS



OPERATION:

1. Do not put hands or feet near, under or inside rotating parts.
2. Exercise extreme caution when operating on or crossing gravel drives, walks or roads. Stay alert for hidden hazards or traffic. Do not carry passengers.
3. After striking a foreign object, stop the engine (motor), disconnect the wire from the spark plug(s) and keep wire away to prevent accidental starting. Thoroughly inspect the accessory for any damage and repair damage before restarting and using the accessory.
4. If the unit should start to vibrate abnormally, stop the engine (motor) and check immediately for the cause. Vibration is generally a warning of trouble.
5. Take all possible precautions when leaving the vehicle unattended. Disengage the power take-off, lower the attachment, place the transmission into neutral, set the parking brake, stop the engine and remove the contact key.
6. Do not run the engine indoors, except when starting the engine and for transporting in or out of the building. Do not operate or let motor run in a storage area without ventilation because gas contains carbon monoxide which is odorless, colorless and can cause death.
7. Never use the accessories across the face of slopes, go from top to bottom. Exercise extreme caution when using equipment on slopes. Do not attempt to clear a steep slope.
8. Never tolerate bystanders in the working zone. Never use an accessory in the direction of bystanders, it might throw gravel or debris that can hurt people or damage property.
9. Never operate the accessory at high transport speeds on slippery surfaces. Use care when backing up.
10. Do not carry passengers.
11. Disengage power to the accessory when it is transported or not in use.
12. Never operate the accessory without good visibility or light.

13. Keep the accessory away from heat sources or flames.

MAINTENANCE AND STORAGE

1. When cleaning, repairing or inspecting the vehicle and accessory, make certain that all moving parts have stopped. Disconnect wire from the spark plug(s) and keep wire away to prevent accidental starting.
2. Check all the bolts and components at frequent intervals to make sure that they are properly tightened.
3. Never store a motorized accessory with fuel in the fuel tank inside a building where ignition sources are present such as hot water and space heaters, clothes dryers, and the like. Allow the engine to cool before storing in any enclosure.
4. Always refer to the owner's manual when you store the accessory and vehicle for a prolonged or an unspecified length of time.
5. Maintain or replace safety and instruction labels, as necessary.
6. For winter accessories, (if applicable), let the engine run for a few minutes after clean snow in order to prevent the rotary parts from freezing.
7. Inspect the vehicle's and accessory's air filter every day. Clean it or replace it as necessary. Change the oil more often when working in dusty conditions. See the vehicle's and accessory's owner's manual.



**THIS SYMBOL MEANS
DANGER !
BECOME ALERT !
YOUR SAFETY IS INVOLVED !**

SAFETY DECALS

REPLACE IF DECALS ARE DAMAGED
SEE PARTS BREAKDOWN FOR DECAL LOCATION



Decal # 102124



Decal # 102125



Decal # 102126



Decal # 102127



Decal # 102128

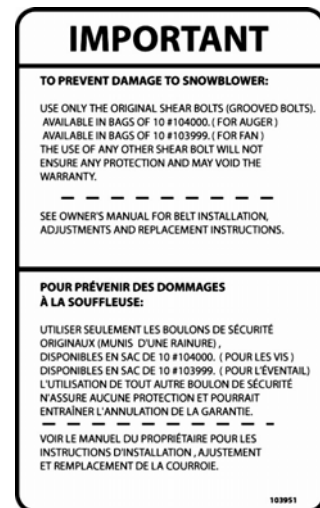

Decal # 103951

ASSEMBLY

TOOLS REQUIRED

1 Wrench 7/16"
1 Ratchet
1 Extension for ratchet
1 Socket 7/16"

STEP 1 **SNOWBLOWER PREPARATION:**

Install the hand guard (item 1) in the chute (item 2) as shown.

Secure in place with two 1/4 x 3/4" hex bolts, two flat washers and two 1/4" flange nuts on the inside.

Tighten firmly.

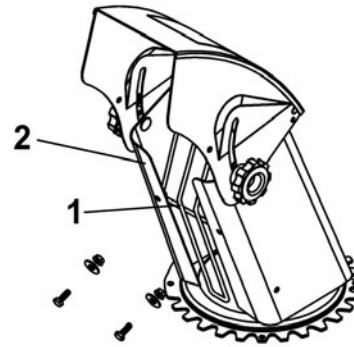

Install hand guard

Before installing the chute (item 1), loosen the two flange nuts (item 2) (down to the last threads) which holds the rotation system (item 3).

Install the rotation ring (item 4) over opening (item 5) as shown and align the notches.

Place the chute (item 1) (facing the rear) and clip the back over the rotation ring then turn the chute towards the front to lock into place.

Reinstall the rotation system by tightening the flange nuts firmly.

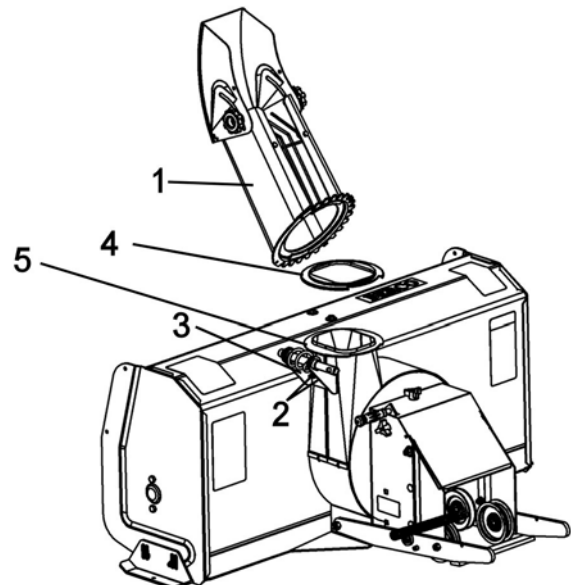

Install chute

ASSEMBLY

STEP 2

SNOWBLOWER INSTALLATION:

Refer to parts breakdown section for parts identification.



WARNING



TO PREVENT INJURIES:

Stop the motor.

Apply parking brake.

Remove the ignition key.

Disconnect the wire from the spark plug(s) and keep away from spark plug(s) to prevent accidental starting.

Attach the snowblower to the subframe as shown.

Make sure the snowblower is pushed in until locked into place by the springs (item 3).

Lift the snowblower.

Turn the tension arm (item 1) towards the back and install the chain (item 2) on the hook (if subframe is equipped with one)

Turn the tension arm towards the front to apply tension on the spring.

Lower the snowblower.

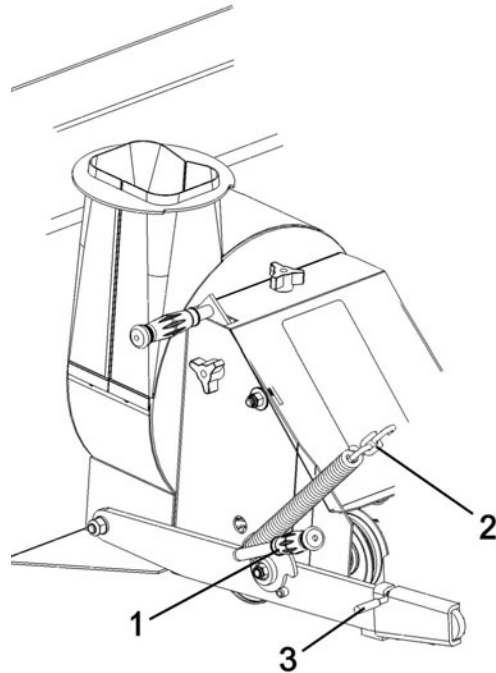

Install snowblower and lift assist spring



CAUTION



The belt tension and lift assist spring arm are spring loaded & need to be held firmly while displacing to prevent injury.

NOTE: See belt installation instructions in the Maintenance section.



WARNING



TO PREVENT INJURIES:

It is the person who installs the drive mechanism responsibility to make sure that when the clutch is disengaged that all moving parts stop.

For more information, do not hesitate to contact the technical support.



CAUTION



Never use the snowblower without the belt guard.

ASSEMBLY

Insert the handgrip (item 1) on the handle as shown.

Insert the handle hook (item 2) into the handle and secure with a 2.5 mm hair pin (item 3) as shown.



Install handle

VERIFY SKID SHOE ADJUSTMENT:

LEVEL PAVED SURFACE: Adjust skid shoes to allow 3/16" to 1/4" clearance (A) between cutting edge and surface.

UNEVEN OR GRAVEL SURFACE: Adjust skid shoes to allow 1/2" to 5/8" clearance (A) between cutting edge and surface.

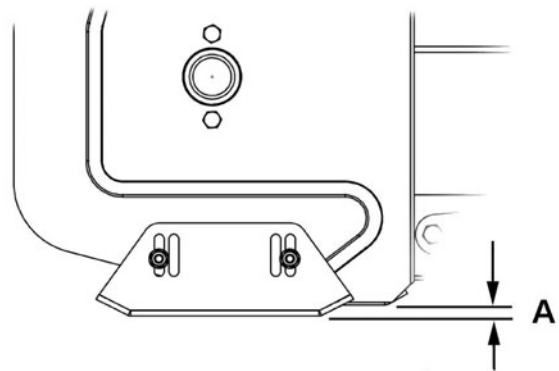

VERIFY TIRE PRESSURE:

Check and adjust tractor tire pressure as follows:

Front tires: 14-15 psi
Back tires: 7-8 psi

Adjust skid shoes

Tire pressure must be even on both sides of tractor.

OPERATION

SNOWBLOWER OPERATION

- a) Make sure the snowblower is clear of snow before engaging the snowblower.
- b) Make sure that the auger and impeller operate freely.
- c) Start the tractor engine.
- d) Before engaging the snowblower drive, always have the engine running at medium R.P.M.
- e) Operate the snowblower at maximum engine R.P.M.

IMPORTANT: USE FULL ENGINE R.P.M. WHEN REMOVING WET OR STICKY SNOW. LOW R.P.M. WILL TEND TO PLUG THE CHUTE.

CONTROLS

CHUTE ROTATION

The chute rotation handle is located to the left of steering wheel. Turning the handle in a clockwise direction, the discharge chute will turn in a clockwise direction or vice versa.

CHUTE DEFLECTOR

Set the angle of the deflector according to the distance the snow must be thrown and to prevent property damage. To change the deflector angle, loosen the two deflector knobs & adjust the deflector to the appropriate angle and retighten the two knobs securely.

SNOW REMOVAL

When removing snow, do not use the snowblower as a dozer blade to push snow. Allow snowblower to ingest snow at its own speed. If the speed of your tractor is too fast, the snowblower may become overloaded and plug. For best results, raise the snowblower and remove a top layer of snow. A second pass with the snowblower will remove the remaining snow.



WARNING



- Do not attempt to clear plugged chute, auger or fan of snow while tractor engine is running.
- Disengage snowblower.
- Lower snowblower onto ground.
- Set the parking brake.
- Stop engine, remove the ignition key, disconnect the wire from spark plug(s) and keep away from spark plug(s) to prevent accidental starting.
- Make sure all moving parts have stopped.
- Do not use hand to unplug chute. Use a 36" (924 mm.) minimum length stick or board.



WARNING



Read the tractor Owner's Manual carefully. Be thoroughly familiar with the controls & proper use of the attachment. Know how to stop the attachment & disengage the controls quickly.



WARNING



- TO PREVENT INJURIES AND FOR MORE TRACTION WHEN USING AN ATTACHMENT:**
- Rear counterweight of 100 lbs. minimum is required to counterbalance the attachment's weight.
 - Tractor manufacturer approved tire chains are required.
 - Do not operate on a slope greater than 10°.
 - When dismantling the attachment remove rear counterweights.

MAINTENANCE



WARNING



TO PREVENT INJURIES:

- Stop the motor.
- Apply parking brake.
- Remove the ignition key.
- Disconnect the wire from the spark plug(s) and keep away from spark plug(s) to prevent accidental starting.

MAINTENANCE

- Check mounting bolts at frequent intervals for proper tightness in order to prevent costly repairs. Make sure your snowblower is in safe working condition.
- Provide adequate blocking before working under snowblower when in raised position.

ADJUSTMENTS

SKID SHOE ADJUSTMENT:

Level Paved Surface: Adjust skid shoes to obtain 3/16" to 1/4" clearance between cutting edge and surface.

Uneven or Gravel Surface: Adjust skid shoes to obtain 1/2" to 5/8" clearance between cutting edge and surface.

LUBRICATION

Apply oil at all pivot points.

Chute Rotation System:

Oil chute base, rotation worm when necessary.

Gear box:

Check the oil annually. If necessary, add AGMA 5 EP or SAE 90 oil.

The gear box should have a total of 155 ml of oil or filled to the rim of the bolt hole when installed on the snowblower.

CLEARING A CLOGGED DISCHARGE CHUTE:

Hand contact with the rotating impeller inside the discharge chute is the most common cause of injury associated with snowblowers. Never use your hand to clean out the discharge chute.

To clear the chute:

- Lower snowblower to the ground and set parking brake.
- SHUT THE ENGINE OFF & REMOVE KEY!
- Wait 10 seconds to be sure the **all moving parts** such as the impeller blades have stopped moving.
- Disconnect wire from the spark plug(s) and keep wire away to prevent accidental starting.
- Always use a clean-out tool of at least 36" in length, NOT YOUR HANDS.

CUTTING EDGE MAINTENANCE

Verify from time to time the wearing on the cutting edge to make sure you do not wear out the base of the snowblower's chassis. This cutting edge is reversible. All you have to do is unscrew the bolts and turn the cutting edge, reinstall and tighten the bolts securely.

AUGERS AND FAN SHEAR BOLT REPLACEMENT

Shear bolts are to be considered a preventive measure and not an assured protection. Operator vigilance is required. Thoroughly inspect the areas where the snowblower is to be used and remove all foreign objects.

To avoid damage to the snowblower:

Use only the original shear bolts (grooved bolts).

#104000 in bags of 10 for the augers.

#103999 in bags of 10 for the fan.

The use of any other shear bolt will not insure any protection and may void the warranty.

IMPORTANT: It is very important to replace the augers in the same position as shown in the drawing before installing the shear bolts.

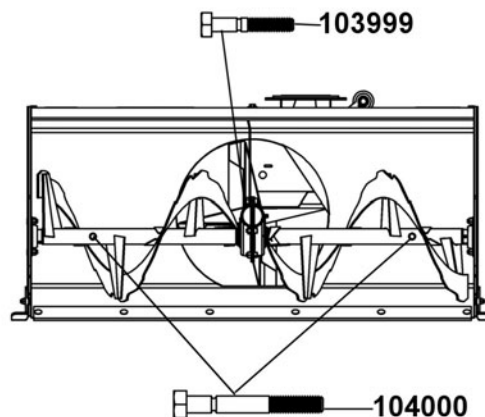

END OF SEASON STORAGE

- Clean snowblower and subframe thoroughly and repaint all parts from which paint has worn.
- List the replacement parts that will be needed for the next season.
- Store the snowblower and the subframe in a dry place.
- Follow the instructions in the Lubrication section.

MAINTENANCE

IMPORTANT:

When aligning or replacing the snowblower pulley (item 1), you must clean the parts and use "Lock-tite" 2760 on the key and the set screws. Tighten firmly.

BELT INSTALLATION, ADJUSTMENT, AND REPLACEMENT: **SNOWBLOWER BELT:**

- a) Lower the snowblower to the ground.
- b) Remove the belt guard.
- c) Loosen the knob (item 10) of the bearing support (item 11).
- d) Install the belt as shown.

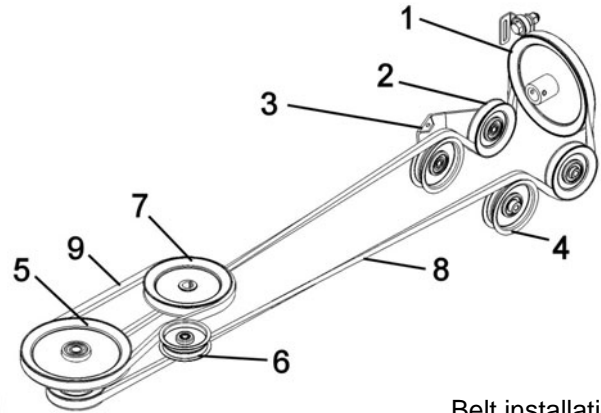

Belt installation

- Item 1: Snowblower pulley
- Item 2: V pulley
- Item 3: Tension arm
- Item 4: Flat pulley
- Item 5: Drive mechanism pulley
- Item 6: Flat pulley
- Item 7: Engine pulley
- Item 8: Snowblower belt
- Item 9: Drive mechanism belt

- e) Adjust the ball bearing support (bracket) (item 11) on the belt. Push on the bearing (item 12) to apply a slight pressure on the back of the belt (just enough to hold the belt in place). It is normal that the bearing is off centre (towards the back of the snowblower) on the pulley. Just make sure that it does not come into contact with the wall of the pulley. Tighten firmly with the knob (item 10).

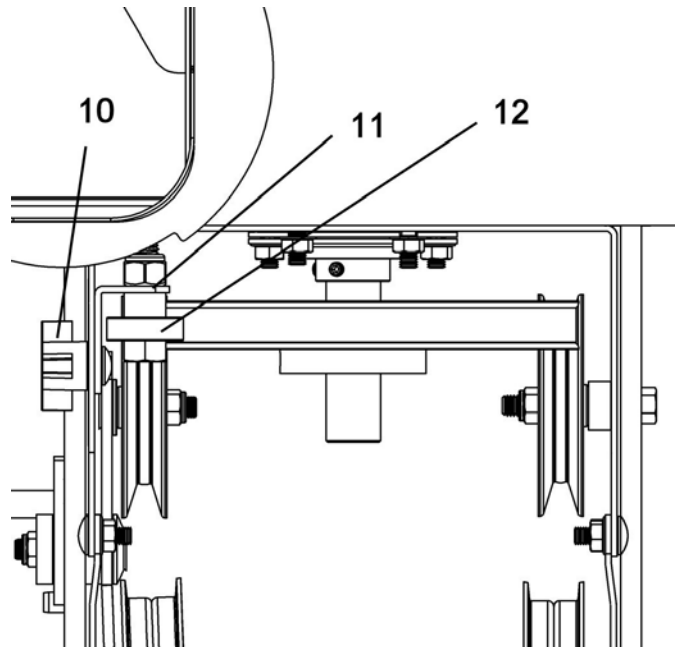

Position the bearing support

MAINTENANCE

- f) Apply tension to the belt by pulling up the tension arm (item 1).
After installation of the snowblower belt, make sure there is enough tension on the belt. To obtain the proper tension, the distance between the coils of the spring should be .25" (1/4") approx.
If not, remove the bolt, sleeve and the spring (item 3) from the original hole and reinstall them in the second hole (item 2). This will apply more tension on the belt helping to prevent it from slipping in the pulleys.
- g) Engage the snowblower for a few seconds under supervision. Stop the engine. Inspect the belt to make sure it does not interfere with any parts; that it is well inserted in the pulleys and that it has not flipped on it's side while still on the pulleys. The V of the belt **must be in** the V of the pulleys. The back of the belt **must rest on** the flat pulleys (D) as shown.
- h) Reinstall the belt guard.
- i) Use genuine belts only, they are specifically fabricated for this application.

NOTE: Belts must be under high tension at all times. If spring is damaged or stretched, you must replace it.

DRIVE MECHANISM BELT:

See subframe manual for belt replacement instructions.



WARNING



TO PREVENT INJURIES:

It is the person who installs the drive mechanism responsibility to make sure that when the clutch is disengaged that all moving parts stop.

For more information, do not hesitate to contact the technical support.

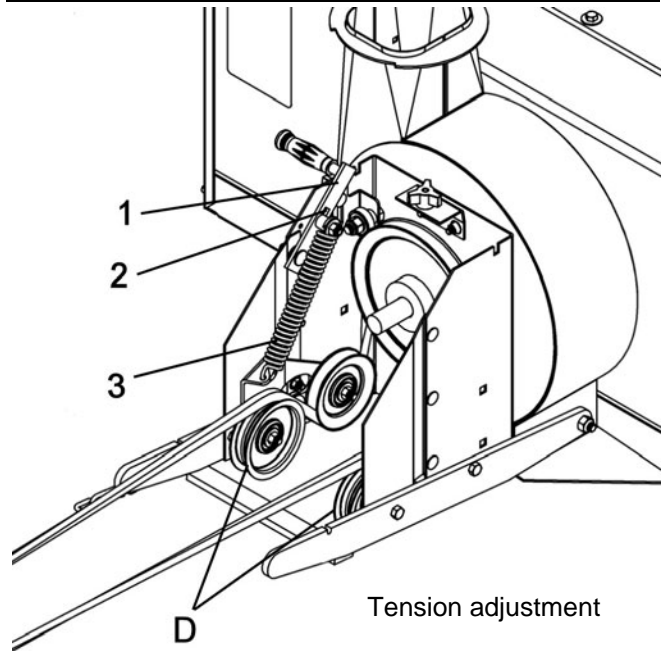

CAUTION



The belt tension and lift assist spring arm are spring loaded & need to be held firmly while displacing to prevent injury.

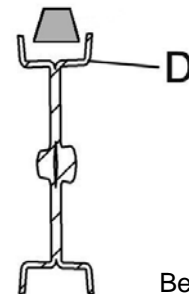

CAUTION



Never use the snowblower without the belt guard.

.25" (1/4") approx.

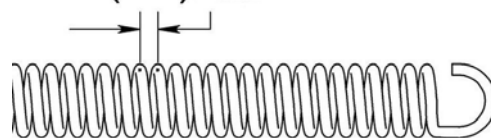

Distance between coils

DISMOUNTING

SNOWBLOWER DISMOUNTING



WARNING



TO PREVENT INJURIES:

Stop the motor.
Apply parking brakes.
Remove the ignition key.
Disconnect the wire from the spark plug(s) and keep away from spark plug(s) to prevent accidental starting.



CAUTION



The belt tension and lift assist spring arm are spring loaded & need to be held firmly while displacing to prevent injury.

- a) Remove the hair pin and the handle from the rotation system.
- b) Remove the belt guard and release the tension on the belt by displacing the tension arm backwards. The tension arm is spring loaded and needs to be held firmly while lowering to prevent injuries. Remove the belt.
- c) Detach the snowblower by removing the lift assist spring and by lifting the two spring locks on the male quick hitch and pulling out the snowblower one side at a time.

TROUBLESHOOTING

PROBLEM	POSSIBLE CAUSES	CORRECTIVE ACTION
One section or both sections of the auger stops turning.	Shear bolts are probably broken.	Replace shear bolt (for identification, see parts list "Snowblower").
Fan stops turning.	Shear bolt is probably broken.	Replace shear bolt (for identification, see parts list "Snowblower").
Snowblower stops turning.	One of the two belts is probably damaged or broken.	Check both belts and replace damaged belt(s) (for instructions, see Maintenance section, Installation, Adjustment and Replacement section).
Belt has burn marks in specific places.	Lack of tension on belt.	Adjust manual clutch cable or replace springs if stretched. To obtain the proper tension, the distance between the coils of the spring should be .25" (1/4"). If not, remove the bolt, sleeve and the spring from the original hole and reinstall them in the second hole. (See Maintenance section, Belt installation, adjustment and replacement)
	Snowblower engaged when plugged.	Make sure the auger & the fan are not frozen or plugged before engaging.
Chute plugs easily.	Tractor engine turning too slowly.	Run engine at full throttle during snowblowing operation.
	Advancing too quickly with tractor.	Allow snowblower to ingest snow at its own speed.
Chute rotation is difficult.	Dirt or ice may be underneath chute.	Dismount chute by removing the rotation worm (for identification, see parts list "Chute with Rotation System"). Turn the chute completely towards the rear and it will disconnect from base. Clean the base of chute and the rotation ring. Lubricate & re-install.

TROUBLESHOOTING

PROBLEM	POSSIBLE CAUSES	CORRECTIVE ACTION
Snowblower digs into ground.	Ground is not frozen or too soft.	Adjust skid shoes lower so they may better support the snowblower. If problem persists, change skid shoes for heavy duty skid shoes (option #700243) which cover more surface and prevents snowblower from digging.
Snowblower does not raise evenly.	<p>Tire pressure uneven from one side to another.</p> <p>Maladjustment of the snowblower.</p>	<p>Verify and adjust tire pressure: Front tires: 14 to 15 psi Rear tires: 7 to 8 psi</p> <p>Loosen male hitch on snowblower (for identification, see parts list "Snowblower").</p> <p>Place a shim (ex.:piece of wood approx. 2" thick) under the lowest side of snowblower which needs to be leveled. Re-tighten bolts.</p>
Snowblower vibrates or is abnormally noisy.	<p>Damaged pulley.</p> <p>Damaged bearing.</p> <p>Damaged fan.</p> <p>Damaged auger.</p>	<p>Replace pulley.</p> <p>Replace bearing.</p> <p>Dismount & repair or replace fan.</p> <p>Replace auger.</p>

PARTS BREAKDOWN / NOMENCLATURE DES PIÈCES CHUTE / GOULOTTE

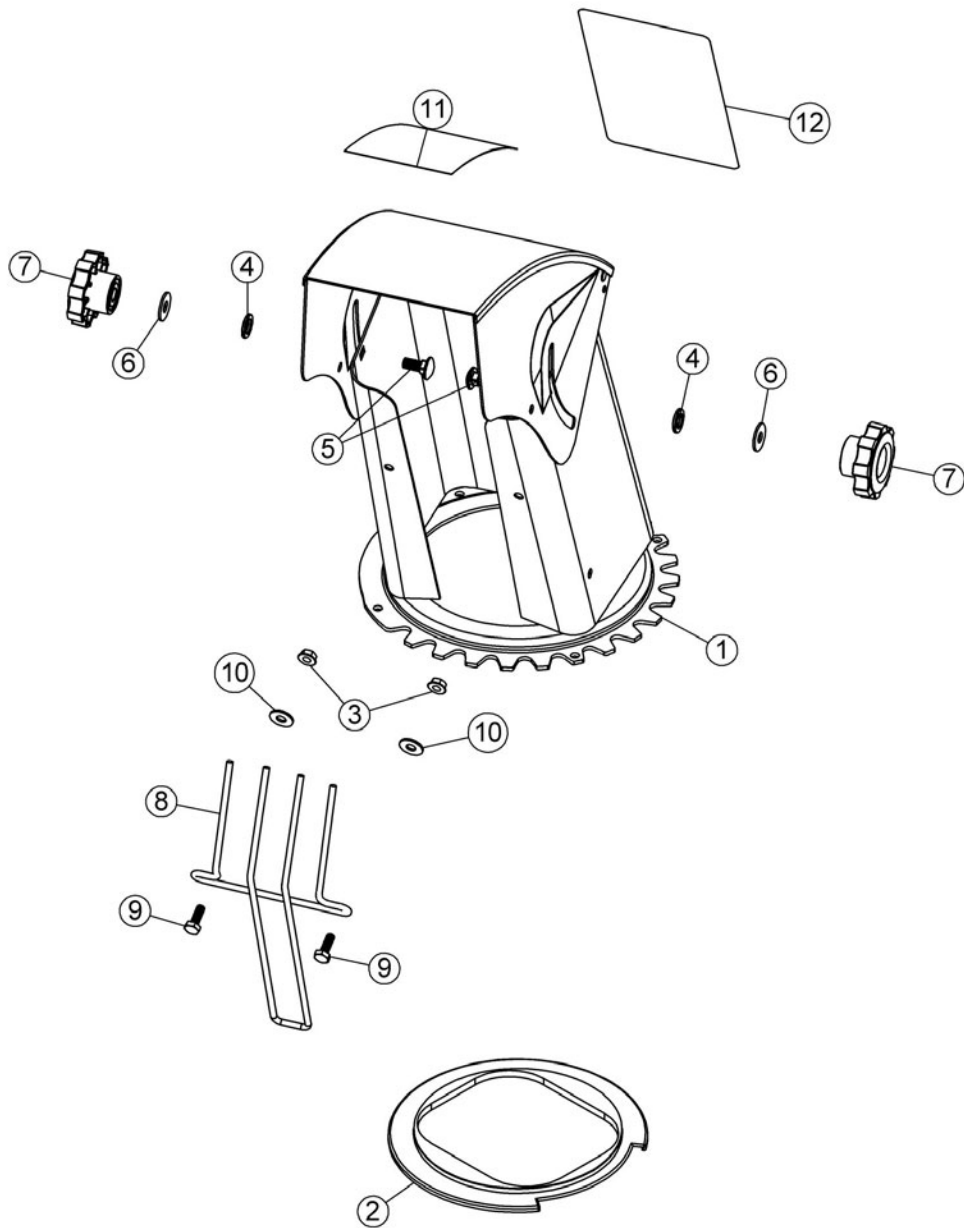

PARTS LIST / LISTE DES PIÈCES

REF. RÉF.	DESCRIPTION	DESCRIPTION	QTY QTÉ	PART # PIÈCE #
1	Chute	Goulotte	1	103936
2	Rotation ring	Anneau de rotation	1	103943
3	Flange nut 1/4" n.c.	Écrou à bride 1/4" n.c.	2	O/L
4	Nylon flat washer 7/16"	Rondelle plate de nylon 7/16"	2	102011
5	Carriage bolt 5/16" n.c. x 3/4"	Boulon à carrosserie 5/16" n.c. x 3/4"	2	O/L
6	Nylon flat washer 11/32"	Rondelle plate de nylon 11/32"	2	102009
7	Knob	Bouton	2	102020
8	Hand guard	Fourche protectrice	1	102012
9	Hex. bolt 1/4" n.c. x 3/4"	Boulon hex. 1/4" n.c. x 3/4"	2	O/L
10	Flat washer 5/16" hole	Rondelle plate 5/16" trou	2	O/L
11	Danger decal	Décalque danger	1	102127
12	Warning decal	Décalque attention	1	102125

O/L = Obtain locally / obtenir localement

PARTS BREAKDOWN / NOMENCLATURE DES PIÈCES SNOWBLOWER / SOUFFLEUSE

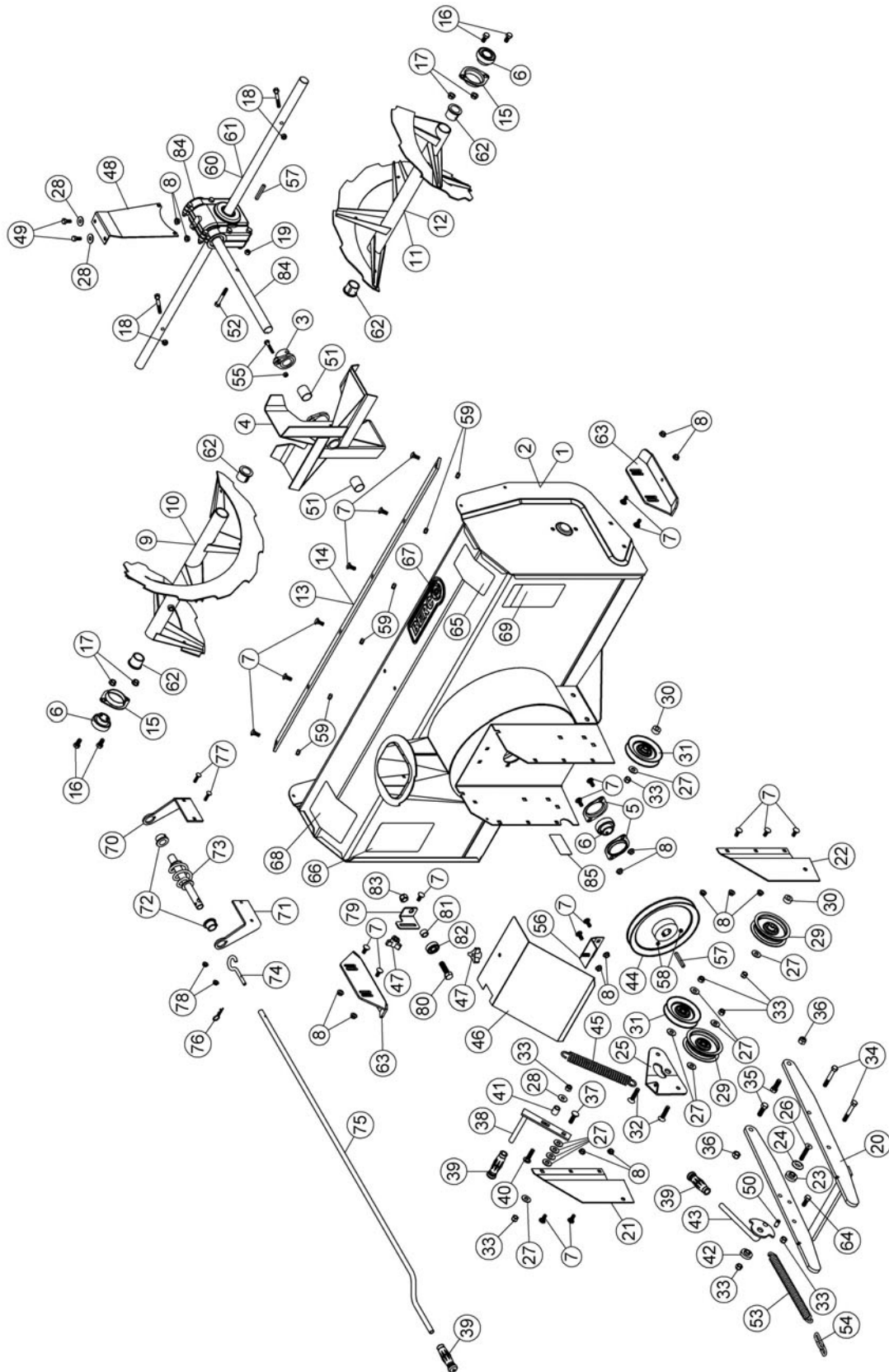

PARTS LIST / LISTE DES PIÈCES

REF. RÉF.	DESCRIPTION	DESCRIPTION	QTY QTÉ	PART # PIÈCE #
1	Frame 44"	Châssis 44"	1	103929
2	Frame 48"	Châssis 48"	1	103954
3	Shear plate	Plaque de cisaillement	1	103933
4	Fan	Éventail	1	103932
5	Flangette	Flangette	2	102213
6	Bearing with set screw	Roulement à billes avec vis à pression	3	102755
7	Carriage bolt 5/16" n.c. x 3/4"	Boulon à carrosserie 5/16" n.c. x 3/4"	20	O/L
8	Flange nut 5/16" n.c.	Écrou à bride 5/16" n.c.	15	O/L
9	Auger 44" left	Vis 44" gauche	1	104760
10	Auger 48" left	Vis 48" gauche	1	104765
11	Auger 44" right	Vis 44" droite	1	104761
12	Auger 48" right	Vis 48" droite	1	104766
13	Cutting edge 44"	Racloir 44"	1	102101
14	Cutting edge 48"	Racloir 48"	1	103187
15	Flangette	Flangette	2	102680
16	Hex. bolt 3/8" n.c. x 3/4"	Boulon hex. 3/8" n.c. x 3/4"	4	O/L
17	Flange nut 3/8" n.c.	Écrou à bride 3/8" n.c.	4	O/L
18	Shear bolt / N.I.L.N. (auger) pkg-10	Boulon de séc. / É.G.N. (vis) pqt-10	2	104000
19	Nylon insert lock nut 5/16" n.c.	Écrou à garniture de nylon 5/16" n.c.	1	O/L
20	Male hitch	Attache mâle	1	103949
21	Left plate	Plaque gauche	1	103934
22	Right plate	Plaque droite	1	103935
23	Flange washer	Rondelle à bride	1	102081
24	Special washer	Rondelle plate spécial	1	103042
25	Tension lever	Levier de tension	1	103938
26	Hex socket f.h. cap screw 3/8" n.c. x 2"	Vis a pression hex. t.p. 3/8" n.c. x 2"	1	O/L
27	Flat washer 7/16" hole	Rondelle plate 7/16" trou	11	O/L
28	Flat washer 3/8" hole	Rondelle plate 3/8" trou	3	O/L
29	Flat pulley	Poulie plate	2	102765
30	Sleeve	Douille	2	103939

O/L = Obtain locally/obtenir localement

PARTS LIST / LISTE DES PIÈCES

REF. RÉF.	DESCRIPTION	DESCRIPTION	QTY QTÉ	PART # PIÈCE #
31	V pulley	Poulie en V	2	102766
32	Hex socket f.h. cap screw 3/8" n.c. x 1-3/4"	Vis a pression hex. t.p. 3/8" n.c. x 1-3/4"	2	O/L
33	Nylon insert lock nut 3/8" n.c.	Écrou à garniture de nylon 3/8" n.c.	8	O/L
34	Hex. bolt 3/8" n.c. x 2 1/2"	Boulon hex 3/8" n.c. x 2 1/2"	2	O/L
35	Hex. bolt 7/16" n.c. x 1 1/4"	Boulon hex. 7/16" n.c. x 1 1/4"	2	O/L
36	Nylon insert lock nut 7/16" n.c.	Écrou à garniture de nylon 7/16" n.c.	2	O/L
37	Carriage bolt 3/8" n.c. x 1 1/4"	Boulon à carrosserie 3/8" n.c. x 1 1/4"	1	O/L
38	Tension arm	Bras de tension	1	103026
39	Handgrip	Poignée	3	102062
40	Carriage bolt 3/8" n.c. x 1-1/2"	Boulon à carrosserie 3/8" n.c. x 1 1/2"	1	O/L
41	Sleeve	Douille	1	103028
42	Flange washer	Rondelle à bride	1	103481
43	Tension arm	Bras de tension	1	103947
44	V pulley	Poulie en V	1	103740
45	Spring	Ressort	1	102861
46	Belt guard	Garde-courroie	1	103937
47	Knob	Bouton	2	103027
48	Gear box support	Support de boîte d'engrenage	1	104746
49	Hex. bolt 5/16" n.c. x 3/4"	Boulon hex. 5/16" n.c. x 3/4"	2	O/L
50	Roll pin 3/8" x 3/4"	Goupille roulée 3/8" x 3/4"	1	O/L
51	Oil lite bushing	Coussinet imprégné d'huile	2	102784
52	Hex. bolt 5/16" n.c. x 2 1/4" GR8	Boulon hex. 5/16" n.c. x 2 1/4" GR8	1	O/L
53	Spring	Ressort	1	103073
54	Chain	Chaîne	1	103950
55	Shear bolt / N.I.L.N. (fan) pkg-10	Boulon de séc./ É.G.N. (éven.) pqt-10	1	103999
56	Belt guard support	Support de garde-courroie	1	103990
57	Key 1/4" x 1/4" x 2"	Clé 1/4" x 1/4" x 2"	2	102922
58	Hex. socket set screw 5/16" n.c. x 5/16"	Vis à pression hex. 5/16" n.c. x 5/16"	2	O/L
59	Stover lock nut 5/16" n.c.	Écrou de blocage 5/16" n.c.	6	O/L
60	Shaft 44"	Arbre 44"	1	104720

O/L = Obtain locally/obtenir localement

PARTS LIST / LISTE DES PIÈCES

REF. RÉF.	DESCRIPTION	DESCRIPTION	QTY QTÉ	PART # PIÈCE #
61	Shaft 48"	Arbre 48"	1	104721
62	Rotation bushing	Coussinet de rotation	4	103946
63	Skid shoe	Patin	2	103188
64	Hex. bolt 3/8" n.c. x 1"	Boulon hex. 3/8" n.c. x 1"	1	O/L
65	Danger decal	Décalque danger	1	102126
66	Shear bolt decal	Décalque boulon de sécurité	1	103951
67	Berco decal	Décalque Berco	1	102471
68	Warning decal	Décalque attention	1	102124
69	Danger decal	Décalque danger	1	102128
70	Worm support	Support spirale	1	103941
71	Worm support	Support spirale	1	103942
72	Rotation bushing	Coussinet de rotation	2	103945
73	Rotation worm	Spirale de rotation	1	102005
74	Handle hook	Crochet de manivelle	1	102006
75	Handle	Manivelle	1	102061
76	Hair pin 2.5mm	Goupille à ressort 2.5mm	1	102013
77	Carriage bolt 1/4" n.c. x 1"	Boulon à carrosserie 1/4" n.c. x 1"	2	O/L
78	Flange nut 1/4" n.c.	Écrou à bride 1/4" n.c.	2	O/L
79	Bracket	Fixation	1	104734
80	Hex. bolt 1/2" n.c. x 1 3/4"	Boulon hex. 1/2" n.c. x 1 3/4"	1	O/L
81	Bushing	Coussinet	1	102225
82	Bearing	Roulement à billes	1	104624
83	Nylon Insert lock Nut 1/2" n.c.	Écrou à garniture de nylon 1/2" n.c.	1	O/L
84	Gear box left rotation	Boîte d'engrenage rotation gauche	1	104718
85	Serial number	Numéro de série	1	REF

O/L = Obtain locally/obtenir localement

TORQUE SPECIFICATION TABLE

GENERAL TORQUE SPECIFICATION TABLE USE THE FOLLOWING TORQUES WHEN SPECIAL TORQUES ARE NOT GIVEN

NOTE: These values apply to fasteners as received from supplier, dry or when lubricated with normal oil. They do not apply if special graphited or moly disulphide greases or other extreme pressure lubricants are used. This applies to both UNF and UNC threads.

SEE Grade No.		2				5				8 *			
BOLT HEAD IDENTIFICATION MARKS AS PER GRADE NOTE MANUFACTURING MARKS WILL VARY		TORQUE				TORQUE				TORQUE			
BOLT SIZE		POUNDS FEET		NEWTON-METERS		POUNDS FEET		NEWTON-METERS		POUNDS FEET		NEWTON-METERS	
Inches	Millimetre	Min.	Max.	Min.	Max.	Min.	Max.	Min.	Max.	Min.	Max.	Min.	Max.
1/4"	6.35	5	6	6.8	8.13	9	11	12.2	14.9	12	15	16.3	30.3
5/16"	7.94	10	12	13.6	16.3	17	20.5	23.1	27.8	24	29	32.5	39.3
3/8"	9.53	20	23	27.1	31.2	35	42	47.5	57	45	54	61	73.2
7/16"	11.11	30	35	40.7	47.4	54	64	73.2	86.8	70	84	94.9	113.9
1/2"	12.7	45	52	61	70.5	80	96	108.5	130.2	110	132	149.2	179
9/16"	14.29	65	75	88.1	101.6	110	132	149.2	179	160	192	217	260.4
5/8"	15.88	95	105	128.7	142.3	150	180	203.4	244.1	220	264	298.3	358
3/4"	19.05	150	185	203.3	250.7	270	324	366.1	439.3	380	456	515.3	618.3
7/8"	22.23	160	200	216.8	271	400	480	542.4	650.9	600	720	813.6	976.3
1"	25.4	250	300	338.8	406.5	580	696	786.5	943.8	900	1080	1220.4	1464.5

*Thick nuts must be used with grade 8 bolts

METRIC BOLT TORQUE SPECIFICATIONS							
Size Screw	Grade No.	Pitch (mm)	COARSE THREAD		FINE THREAD		
			Pounds Feet	Newton-Meters	Pitch (mm)	Pounds Feet	Newton-Meters
M6	4T	1.00	3.6 - 5.8	4.9 - 7.9	-	-	-
	7T		5.8 - 9.4	7.9 - 12.7		-	-
	8T		7.2 - 10	9.8 - 13.6		-	-
M8	4T	1.25	7.2 - 14	9.8 - 19	1.00	12 - 17	16.3 - 23
	7T		17 - 22	23 - 29.8		19 - 27	25.7 - 36.6
	8T		20 - 26	27.1 - 35.2		22 - 31	29.8 - 42
M10	4T	1.50	20 - 25	27.1 - 33.9	1.25	20 - 29	27.1 - 39.3
	7T		34 - 40	46.1 - 54.2		35 - 47	47.4 - 63.7
	8T		38 - 46	51.5 - 62.3		40 - 52	54.2 - 70.5
M12	4T	1.75	28 - 34	37.9 - 46.1	1.25	31 - 41	42 - 55.6
	7T		51 - 59	69.1 - 79.9		56 - 68	75.9 - 92.1
	8T		57 - 66	77.2 - 89.4		62 - 75	84 - 101.6
M14	4T	2.00	49 - 56	66.4 - 75.9	1.50	52 - 64	70.5 - 86.7
	7T		81 - 93	109.8 - 126		90 - 106	122 - 143.6
	8T		96 - 109	130.1 - 147.7		107 - 124	145 - 168
M16	4T	2.00	67 - 77	90.8 - 104.3	1.50	69 - 83	93.5 - 112.5
	7T		116 - 130	157.2 - 176.2		120 - 138	162.6 - 187
	8T		129 - 145	174.8 - 196.5		140 - 158	189.7 - 214.1
M18	4T	2.00	88 - 100	119.2 - 136	1.50	100 - 117	136 - 158.5
	7T		150 - 168	203.3 - 227.6		177 - 199	239.8 - 269.6
	8T		175 - 194	237.1 - 262.9		202 - 231	273.7 - 313
M20	4T	2.50	108 - 130	146.3 - 176.2	1.50	132 - 150	178.9 - 203.3
	7T		186 - 205	252 - 277.8		206 - 242	279.1 - 327.9
	8T		213 - 249	288.6 - 337.4		246 - 289	333.3 - 391.6

OPTIONS & ATTACHMENTS

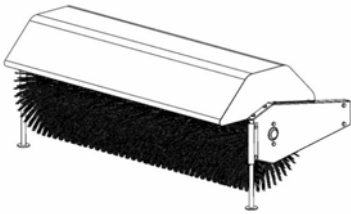

ROTARY BROOM
#700380 with nylon brush
#700381 with polypropylene brush.

Fits on same subframe as snowblower or utility blade.
Requires an adaptor.

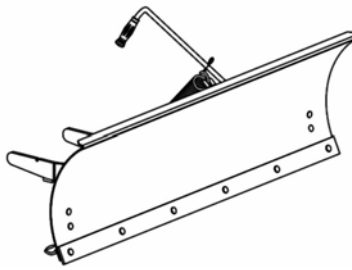

UTILITY BLADE #700266

Mounts on the same subframe as the snowblower & rotary broom.

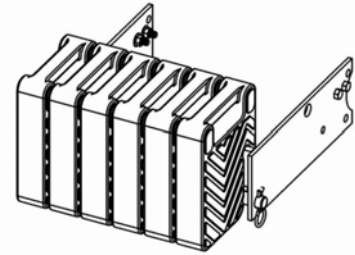

COUNTERWEIGHT

#700240 Universal rear weights
#700246 Rear weights Electrolux
Required for safety and traction.
Counter-balances weight of attachment.

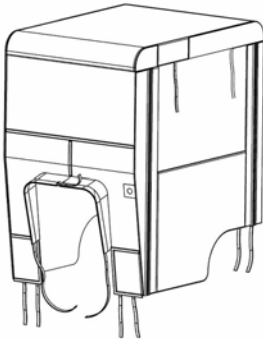

TRACTOR WINTER CAB
#700423

Universal type fits on a wide variety of lawn and garden tractors.

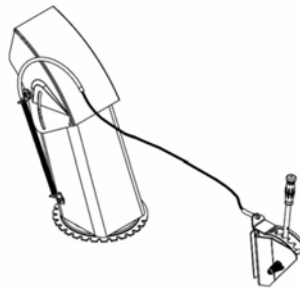

MANUAL DEFLECTOR ADJUSTMENT KIT #700239

ELECTRIC DEFLECTOR ADJUSTMENT KIT #700526
Adjusts height at which snow is thrown from the driver's seat.

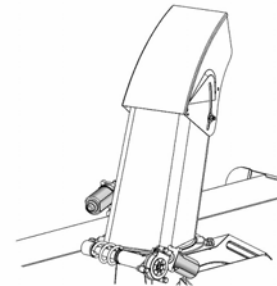

ELECTRIC CHUTE ROTATION & DEFLECTOR KIT #700518
Allows to turn chute and adjust deflector electrically from driver's seat.

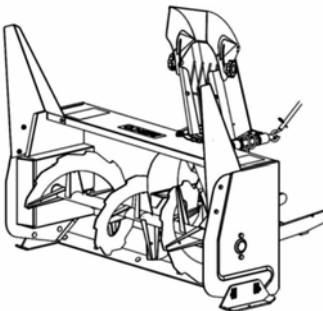

SNOW DRIFT CUTTER

#700260 for Northeast snowblower.
Facilitates and increases snow intake.
Pkg. of 2

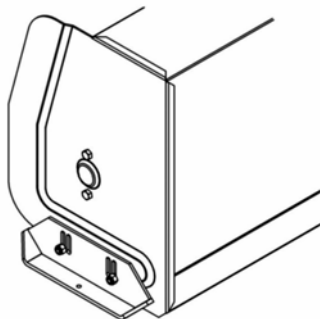

HEAVY DUTY SKID SHOES #700243

For gravel driveways.
Pkg. of 2

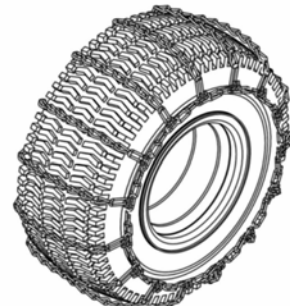

TIRE CHAINS

Two link spacing.
Required for traction and safety.
Pkg. of 2



***WHEN PERFORMANCE
& DEPENDABILITY
ARE NON NEGOTIABLE!***

Bercomac Limitée
92, Fortin North, Adstock, Quebec, Canada, G0N 1S0

WWW.BERCOMAC.COM

PRINTED IN CANADA