



OWNER'S MANUAL
Model Number

700370-1



BERCO
Subframe
for
JOHN DEERE

SERIES LX255, 266, 277, 277AWS, 279, 280, 288, 289

SERIES GT225, 235, 245, 262, 275

GX255 and G-100

Tractors

* ASSEMBLY

* REPAIR PARTS

* OPERATION

* MAINTENANCE

CAUTION:

**READ & FOLLOW ALL SAFETY RULES & INSTRUCTIONS
BEFORE OPERATING YOUR EQUIPMENT**

WARRANTY

LIMITED ONE YEAR ON BERCO TRACTOR ATTACHMENTS

For one year from date of purchase, Bercomac Limitée will repair or replace free of charge at Bercomac's option, any parts which are defective as a result of defective materials or faulty workmanship.

COMMERCIAL OR RENTAL USE:

Warranty on Berco attachments used for commercial or rental purposes is limited to 90 days.

This warranty does NOT cover:

- * Wear items, such as shear pins and belts.
- * Repairs due to customer abuse or neglect.
- * Pre-delivery set-up.
- * In home service.

Warranty service is available by returning the "Berco" attachment to the authorized dealer.

BERCOMAC Limitée
92 Fortin N, Adstock, Québec, Canada, G0N 1S0

TABLE OF CONTENTS

	PAGE
INTRODUCTION	2
SAFETY PRECAUTIONS	3
ASSEMBLY	
Step 1: Subframe Preparation	5
Subframe Installation ..	7
Step 2: Snowblower Installation	8
Rotary Broom Installation	11
Utility Blade Installation	14
MAINTENANCE & DISMOUNTING	
Maintenance	16
Belt Adjustment	16
Subframe Dismounting	16
End of Season Storage	16
TORQUE SPECIFICATION TABLE	17
PARTS BREAKDOWN AND LISTS	
Push frame	18
Subframe	20
OPTIONS	23
TROUBLESHOOTING	
See attachment owner's manual for this section. (Snowblower, Utility Blade, Rotary Broom)	

INTRODUCTION

TO THE PURCHASER

This new attachment was carefully designed to give years of dependable service. This manual has been provided to assist in the safe operation and servicing of your attachment.

NOTE: All photographs and illustrations in the manual may not necessarily depict the actual models or attachment, but are intended for reference only and are based on the latest product information available at the time of publication.

Familiarize yourself fully with the safety recommendations and operating procedures before putting the machine to use. Carefully read, understand and follow these recommendations and insist that they be followed by those who will use this attachment.

9

THIS SAFETY ALERT SYMBOL IDENTIFIES AN IMPORTANT SAFETY MESSAGE IN THIS MANUAL THAT HELPS YOU AND OTHERS AVOID PERSONAL INJURY OR EVEN DEATH. DANGER, WARNING, AND CAUTION ARE SIGNAL WORDS USED TO IDENTIFY THE LEVEL OF HAZARD. HOWEVER, REGARDLESS OF THE HAZARD, BE EXTREMELY CAREFUL.

DANGER: Signals an extreme hazard that will cause serious injury or death if recommended precautions are not followed.

WARNING: Signals a hazard that may cause serious injury or death if the recommended precautions are not followed.

CAUTION: Signals a hazard that may cause minor or moderate injury if the recommended precautions are not followed.

Record your attachment serial number and purchase date in the section reserved below (there is no serial number on the subframe). Your dealer requires this information to give you prompt, efficient service when ordering replacement parts. Use only genuine parts when replacements are required.

If warranty repairs are required please present this registration booklet and original sales invoice to your selling dealer for warranty service.

This manual should be kept for future reference.

Please check if you have received all the parts for your kit with the list of the bag and the list of the box.

SERIAL NUMBER : _____

PURCHASE DATE : _____

In this manual, right and left sides are determined by sitting on the tractor seat facing forward.

In this manual, "attachment" means accessories that you install on the tractor, such as, snowblower, rotary broom, blade, rotary tiller, cab, subframe, etc...

SAFETY PRECAUTIONS

Careful operation is your best insurance against an accident. Read this section carefully before operating the tractor and attachment. All operators, no matter how experienced they may be, should read this and other manuals related to the tractor and attachments before operating. It is the owner's legal obligation to instruct all operators in safe operation.

TRAINING

9 This symbol, "Safety Alert Symbol", is used throughout this manual and on the attachment safety labels to warn of the possibility of personal injury. Please take special care in reading and understanding the safety precautions before operating the attachment or the tractor.

1. Read this Owner's Manual carefully. Be thoroughly familiar with the controls and proper use of the attachment. Know how to stop the unit and disengage the controls quickly.
2. Never allow children to operate attachment. Never allow adults to operate attachment without proper instructions.
3. No one should operate the unit while intoxicated or while taking medication that impairs the senses or reactions.
4. Keep the area of operation clear of all persons, particularly small children and pets.

PREPARATION

1. Disengage all clutches and shift into neutral before starting engine.
2. Handle fuel with care, it is highly flammable.
 - a) Use approved fuel container.
 - b) Never add fuel to a running engine or hot engine
 - c) Fill fuel tank outdoors with extreme care. Never fill fuel tank indoors.
 - d) Replace fuel cap securely and wipe up spilled fuel.
3. Never attempt to make any adjustments while engine is running (except where specifically recommended by manufacturer).

4. Always wear safety glasses or eye shields during operation or while performing an adjustment or repairs to protect eyes from foreign objects that may be thrown from the machine.

OPERATION

1. Do not run engine indoors except when starting engine and transporting attachment, in or out of building. Do not operate or let motor run in a storage area without ventilation because gas contains carbon monoxide which is odourless, colourless and can cause death.
2. Do not carry passengers on attachment or tractor.
3. Take all possible precautions when leaving the machine unattended. Lower the attachment, shift into neutral, set the parking brake, stop the engine and remove the key. Wait for all moving parts to stop.
4. You must use manufacturer approved rear counterweights, minimum 100 lbs., for better traction and safety at all times when you have an attachment installed in front.
5. Never operate the attachment without good visibility or light.

SAFETY PRECAUTIONS

MAINTENANCE AND STORAGE

1. Check shear bolts, mounting bolts, etc..., at frequent intervals for proper tightness to be sure attachment is in safe working condition.
2. Never store the machine with fuel in the tank inside a building where ignition sources are present, such as hot water tanks, space heaters, clothes dryers and the like. Allow engine to cool before storing in any enclosure.
3. Maintain or replace safety and instructions labels, as necessary.

WHENEVER YOU SEE THIS SYMBOL

9

IT MEANS:

WARNING!

BECOME ALERT !

YOUR SAFETY IS INVOLVED!

9

WARNING

9

FOR YOUR SECURITY:

Read the attachment owner's manual for safety precautions and rules.

Follow the assembly and operation instructions.

ASSEMBLY

STEP 1

SUBFRAME PREPARATION

IMPORTANT: TORQUE ALL BOLTS ACCORDING TO TORQUE SPECIFICATION TABLE (SEE TABLE OF CONTENTS) WHEN STATED: TIGHTEN FIRMLY. REFER TO PARTS BREAKDOWN SECTION FOR PARTS IDENTIFICATION.

NOTE: The mower deck must be removed to install the subframe.

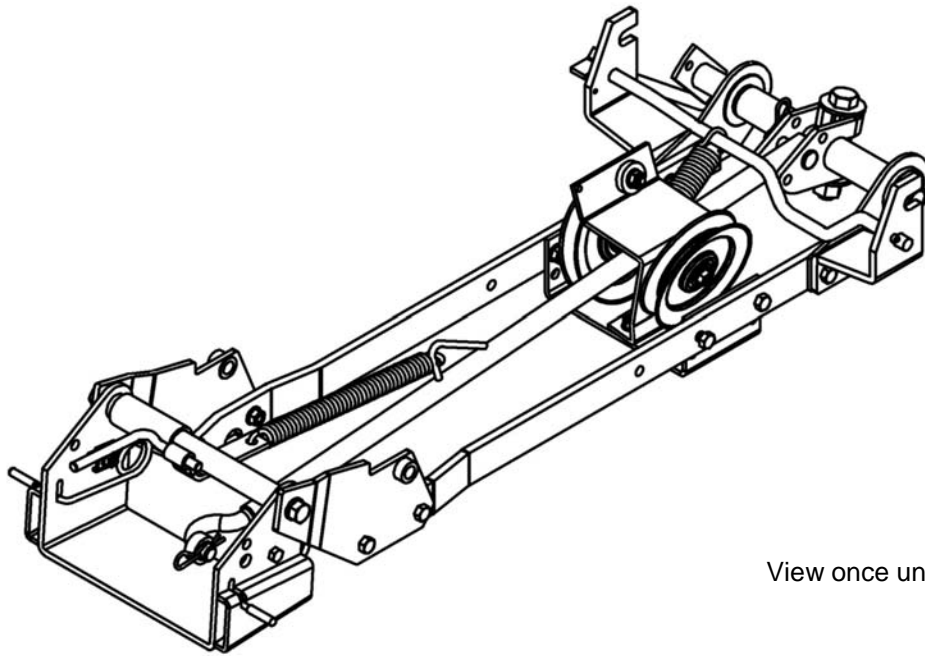

View once unpacked

IF YOUR TRACTOR IS NOT EQUIPPED WITH MOUNTING PINS:

Remove the bolt that holds the left hand side mower lift arm (item 1). Reinstall the lift arm by inserting (as shown) the mounting pin (item 2), original sleeve (item 4) and flat washer (item 3) from the tractor.

Secure with the original nut inside the tractor frame.

Do the same operation on the right side.

Tighten firmly.

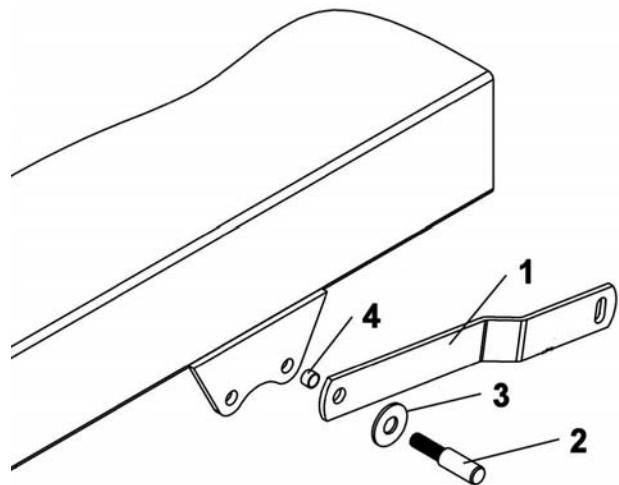

Install the mounting pins

ASSEMBLY

Install the handle support (item 1) on the left hand side with a 3/8 x 1 1/4" hex bolt (item 2) and flange nut already in place, a 3/8 x 1" hex bolt (item 3) and flange nut. Tighten firmly.

Insert the plastic grommet (item 4) in the handle support.

Install the handgrip (item 5) as shown.

NOTE: For the G-100 model

Unscrew the bolts (items 2 & 6) from each side and raise the pulley support (item 7). Secure it in the second set of holes (item 8) (1.00" higher) with the same bolts.

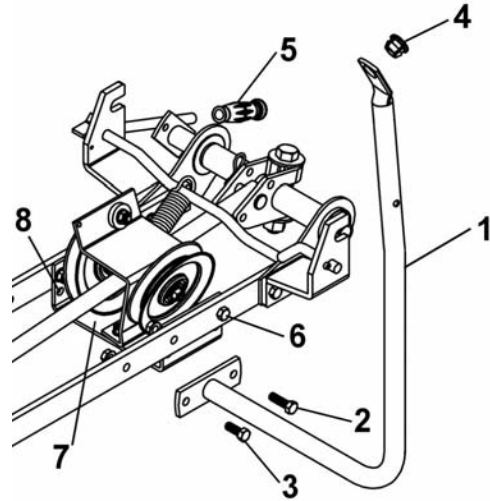

Install handle support

ASSEMBLY

SUBFRAME INSTALLATION:

9

WARNING

9

TO PREVENT INJURIES:

Stop the motor.

Apply parking brake.

Remove the ignition key.

Disconnect the wire from the spark plug(s) and keep away from spark plug(s) to prevent accidental starting.

Slide the subframe under the tractor between the front and back wheels on the left side.

Lift the back part of the subframe and hook the supports (item 1) (as shown) on the mounting pins (item 2).

Lift the front part of the subframe between the tractor supports (item 3).

Secure in place in the square holes or round holes (item 4) depending on the model of tractor with two 0.50 x 1.25" pins (item 5) and two 3mm hair pins (item 6).

IMPORTANT:

Make sure the bolt (item 7) is 7 1/2" to 8 1/4" from the ground.

NOTE: If the holes are not aligned, loosen the supports, install the pins and retighten the support bolts tightly.

If the tractor supports (item 3) are too narrow, loosen the bolts that hold the heat shield.

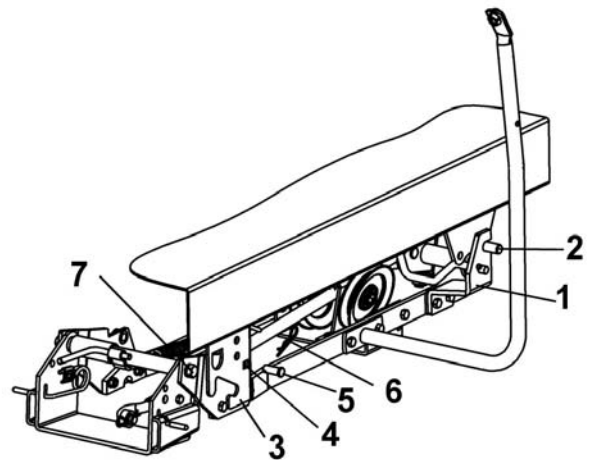

Install the subframe

Install the lift arm (item 1) to the lift arm extension (item 2) with two 5/16 x 3/4" bolts and flange nuts. Tighten firmly.

Install the handgrip (item 3) as shown.

Pull lift arm towards the rear of tractor.

The arm should be 1" outside the mud guard and 2 1/2" above the tire. If not, adjust the arm by unscrewing the bolt (item 4).

IMPORTANT: When adjusted properly, tighten bolt (item 4) very firmly with hinge handle or a torque wrench at 85-90 lbs/ft.

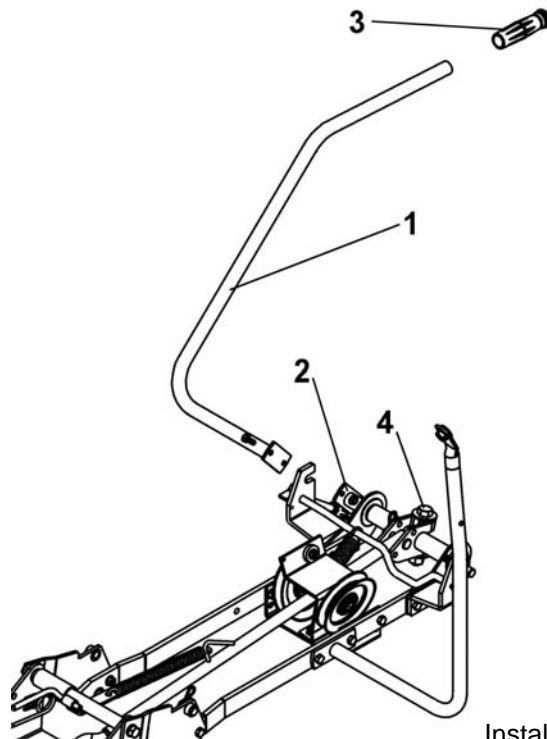

Install lift arm

ASSEMBLY

STEP 2

SNOWBLOWER INSTALLATION:

Refer to snowblower owner's manual, parts breakdown section for parts identification.

9

WARNING

9

FOR YOUR SECURITY:

Read the snowblower owner's manual for safety precautions and rules.

Follow the assembly and operation instructions.

Install the double pulley support (item 1) as shown on the male hitch by using two 5/16 x 1" bolts (item 2) and flange nuts. Tighten the bolts firmly.

9

WARNING

9

TO PREVENT INJURIES:

Stop the motor.

Apply parking brakes.

Remove the ignition key.

Disconnect the wire from the spark plug(s) and keep away from spark plug(s) to prevent accidental starting.

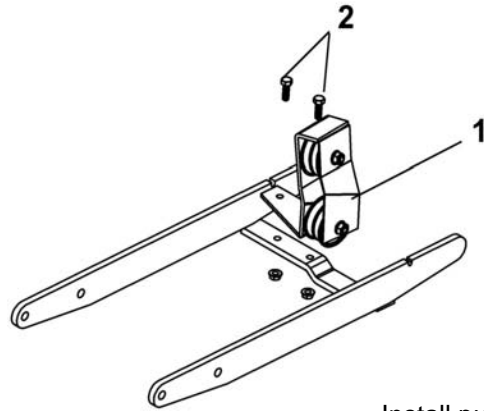

Install pulley support

9

CAUTION

9

TO PREVENT INJURIES:

Always raise the attachment to reduce the tension on the spring before applying or releasing tension on the helper spring. Firmly hold the handle when you release the tension because the arm will kick back due to the tension on the spring.

Lower the tension arm (item 1) to release the tension on the helper spring (item 2) to facilitate snowblower installation.

Install the snowblower to the subframe as shown.

Make sure the snowblower is pushed in until locked into place by the springs (item 3).

NOTE:

Before installing the belt, unhook the spring (item 2) by sliding the spring link (item 4) off the tension arm (item 1).

Put the spring on the ground on the left side.

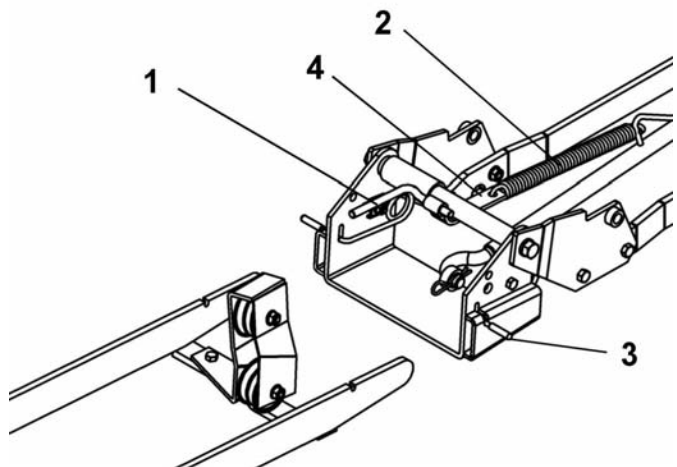

Install the snowblower

ASSEMBLY

9 CAUTION 9

Never use the snowblower without the belt guard.

Remove the belt guard from the back of snowblower.

Move the tension arm (item 8) towards the back to facilitate the belt installation.

Install the belt on the snowblower by inserting it between the two flat pulleys (items 1 & 2) and around the snowblower pulley (item 4). Route the drive belt around the V pulleys (items 5 & 6) and around the tractor drive pulley (item 7). Make sure the belt is not twisted between the pulleys (items 4 & 5).

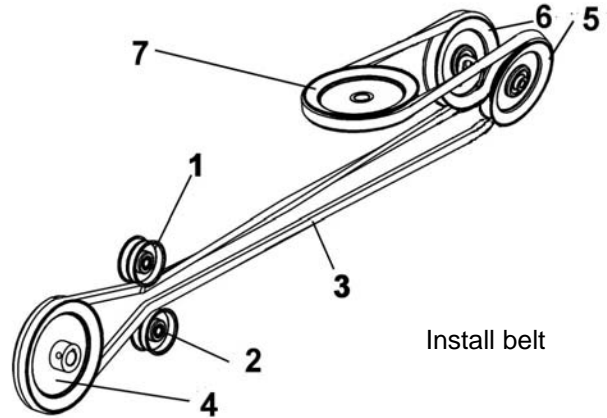

Apply tension on the belt by moving the tension arm (item 8) towards the front and secure with a 3 mm hair pin (item 9) in the hole (item 10).

Check the tension on the belt and adjust if necessary.

See maintenance section for belt adjustment instructions.

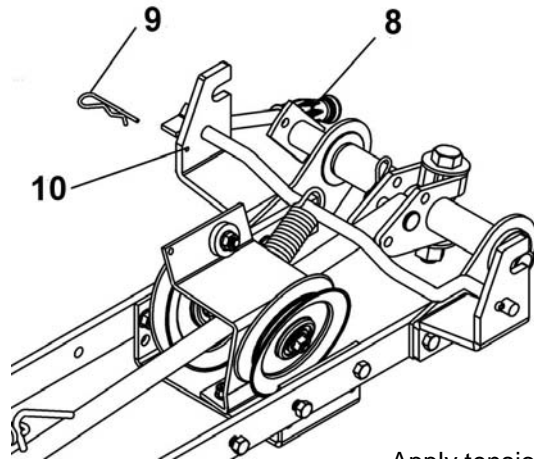

VERIFY BELT ROUTING

- Reconnect the engine's spark plug(s).
- Lower the snowblower to the ground and let it run for a few seconds under supervision.
- Disengage the snowblower and stop the engine.
- Check the belt to make sure it is well inserted in the pulleys and that it has not flipped on its side in the pulleys.
- Reinstall the belt guard.

9 CAUTION 9

TO PREVENT INJURIES:

Always raise the attachment to reduce the tension on the spring before applying or releasing tension on the helper spring. Firmly hold the handle when you release the tension because the arm will kick back due to the tension on the spring.

Reinstall the helper spring as originally installed. Raise the snowblower and pull up the tension arm (item 1). This spring helps to lift the snowblower with little effort.

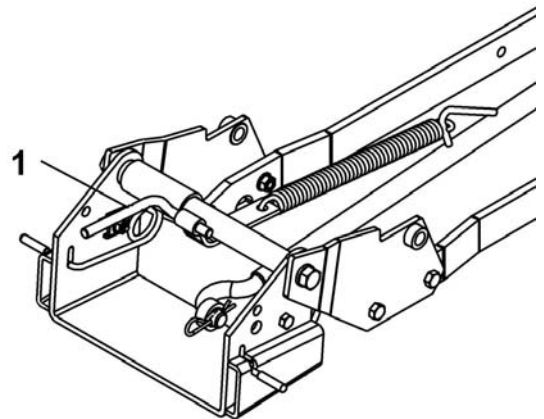

Apply tension to spring

ASSEMBLY

Insert the handle (item 1) into the support (item 2) as shown.

Install the hook (item 3) on the rotation worm (item 4). Insert the hook in the handle (item 1) and secure with a 2.5 mm hair pin (item 5).

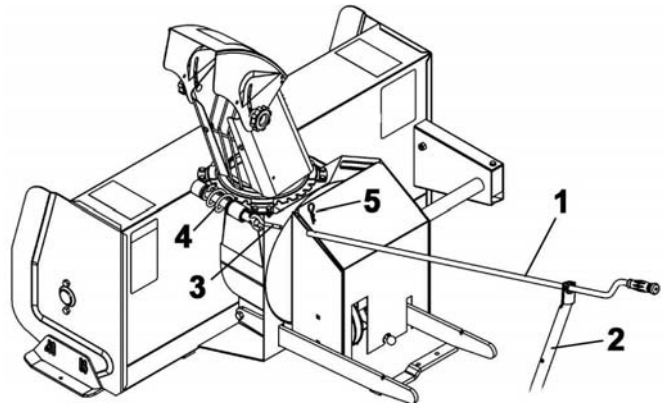

Install handle

VERIFY SKID SHOE ADJUSTMENT:

LEVEL PAVED SURFACE: Adjust skid shoes to allow 3/16 to 1/4" clearance (A) between cutting edge and surface.

UNEVEN OR GRAVEL SURFACE: Adjust skid shoes to allow 1/2 to 5/8" clearance (A) between cutting edge and surface.

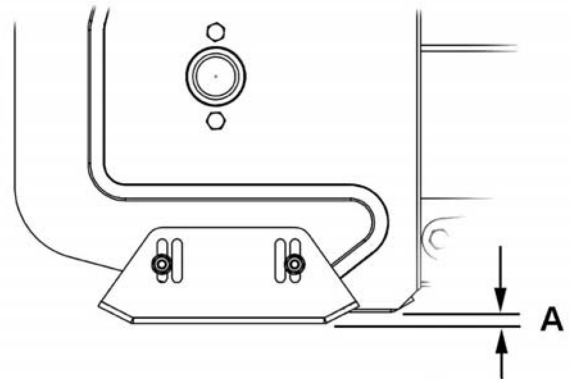

Adjust skid shoes

VERIFY TIRE PRESSURE:

Attachments should raise 3" to 4" above ground (no more, no less) if not check and adjust tractor tire pressure as follows:

Front tires:	20-25 psi
Back tires:	8-10 psi

Tire pressure must be even on both sides of the tractor.

ASSEMBLY

ROTARY BROOM INSTALLATION:

Refer to rotary broom owner's manual, parts breakdown section for parts identification.

9 WARNING 9

FOR YOUR SECURITY:

Read the rotary broom owner's manual for safety precautions and rules.
Follow the assembly and operation instructions.

9 CAUTION 9

TO PREVENT INJURIES:

Always raise the attachment to reduce the tension on the spring before applying or releasing tension on the helper spring. Firmly hold the handle when you release the tension because the arm will kick back due to the tension on the spring.

Lower the arm (item 1) to release the tension on the helper spring (item 2) to facilitate rotary broom installation.

9 WARNING 9

TO PREVENT INJURIES:

Stop the motor.
Apply parking brakes.
Remove the ignition key.
Disconnect the wire from the spark plug(s) and keep away from spark plug(s) to prevent accidental starting.

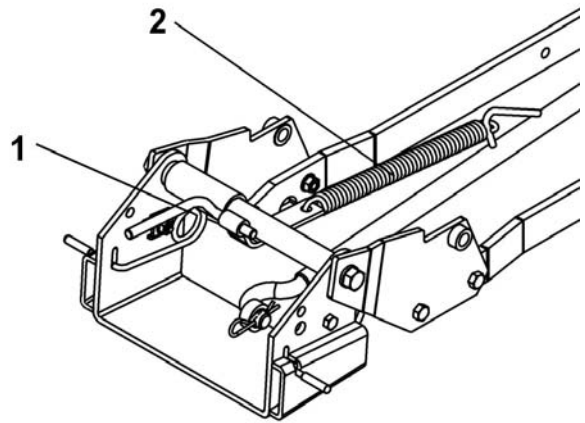

Release tension on the helper spring

Attach the rotary broom to the subframe as shown.

Make sure the rotary broom is pushed in until locked into place by the springs (item 3).

Before installing the belt, unhook the spring (item 2) by sliding the spring link (item 4) off the tension arm (item 1).

Put the spring on the ground on the left side.

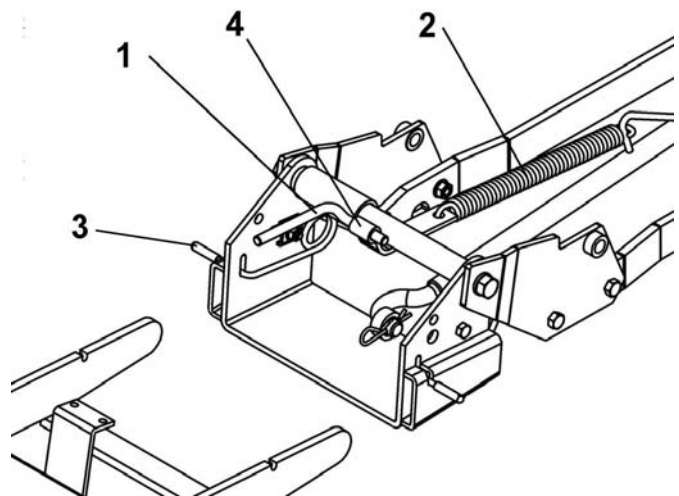

Attach broom to subframe / Remove the helper spring

ASSEMBLY

Install the belt as shown.

Apply tension on the belt by moving the tension arm (item 8) towards the front.
And secure with a 3mm hair pin (item 9) in the hole (item 7).

Check the tension on the belt and adjust if necessary.

See maintenance section for belt adjustment instructions.

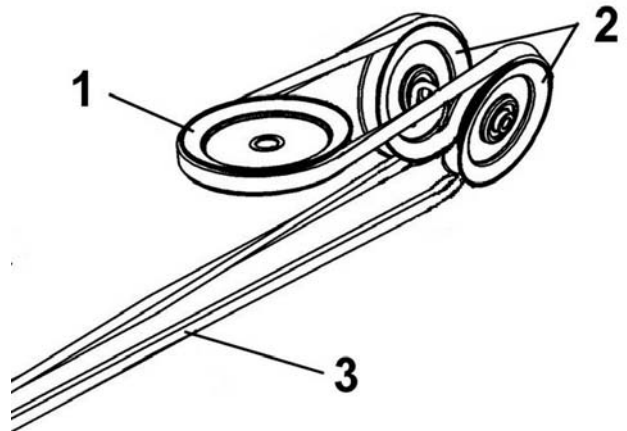

Install belt

VERIFY BELT ROUTING:

- Reconnect the engine's spark plug.
- Lower the rotary broom to the ground and let it run for a few seconds under supervision.
- Disengage the rotary broom and stop the engine.
- Check the belt to make sure it is well inserted in the pulleys and that it has not flipped on its side on the pulleys.
- Reinstall the belt guard.

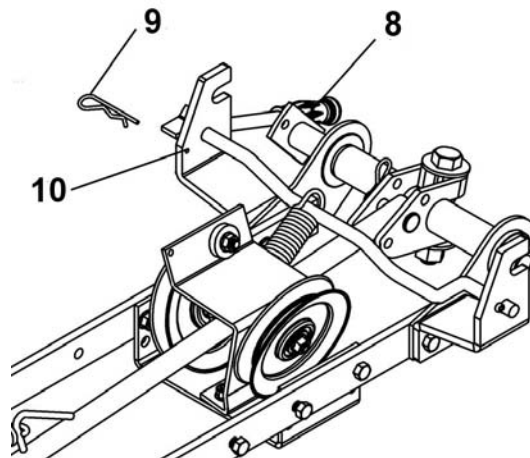

Apply tension on belt

9

CAUTION

9

TO PREVENT INJURIES:

Always raise the attachment to reduce the tension on the spring before applying or releasing tension on the helper spring. Firmly hold the handle when you release the tension because the arm will kick back due to the tension on the spring.

Reinstall the helper spring as originally installed.

Raise the rotary broom and pull up the tension arm (item 1). This spring helps to lift the rotary broom with little effort.

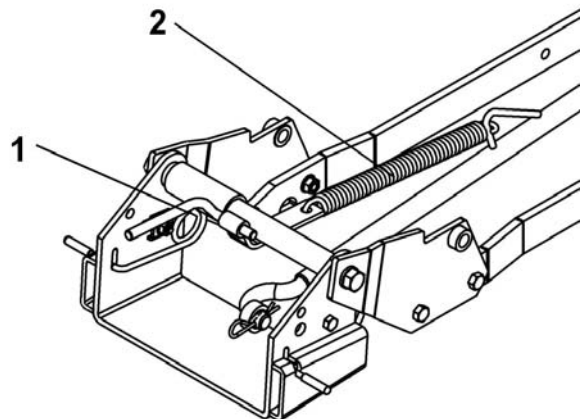

Apply tension on the helper spring

ASSEMBLY

Insert the handle (item 1) into the support (item 2) as shown.

Install the handle (item 1) on the control rod (item 3) as shown and secure with a 2.5 mm hair pin (item 4).

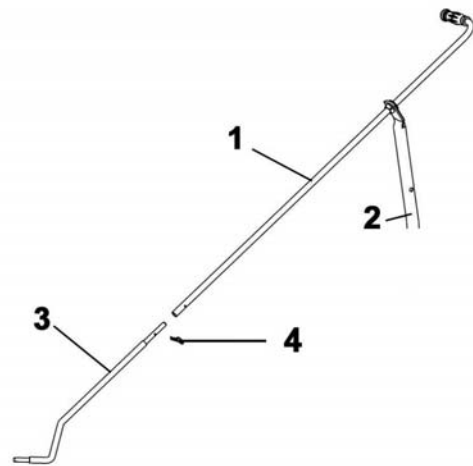

Install handle

VERIFY TIRE PRESSURE:

Attachments should raise 3" to 4" above the ground (no more, no less) if not, check and adjust tractor tire pressure as follows:

Front tires:	20-25 psi
Back tires:	8-10 psi

Tire pressure must be even on both sides of the tractor.

ASSEMBLY

UTILITY BLADE INSTALLATION:

Refer to Utility Blade owner's manual, parts breakdown section for parts identification.

9 WARNING 9

FOR YOUR SECURITY:

Read the Utility Blade owner's manual for safety precautions and rules.
Follow the assembly and operation instructions.

9 CAUTION 9

TO PREVENT INJURIES:

Always raise the attachment to reduce the tension on the spring before applying or releasing tension on the helper spring. Firmly hold the handle when you release the tension because the arm will kick back due to the tension on the spring.

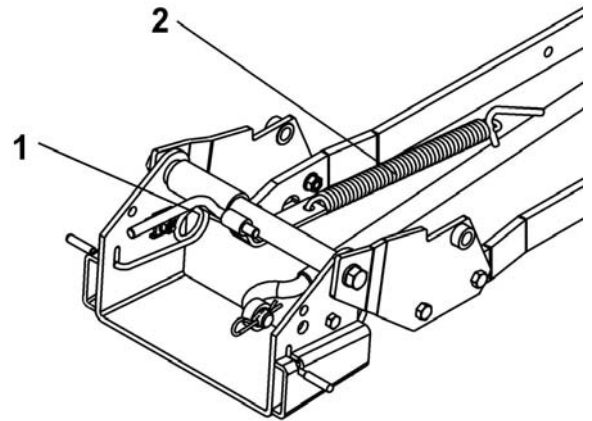

Lower the arm (item 1) to release the tension on the helper spring (item 2) to facilitate blade installation.

Release tension on spring

Attach the blade to the subframe as shown.

Make sure the blade is pushed in until locked into place by the springs (item 1).

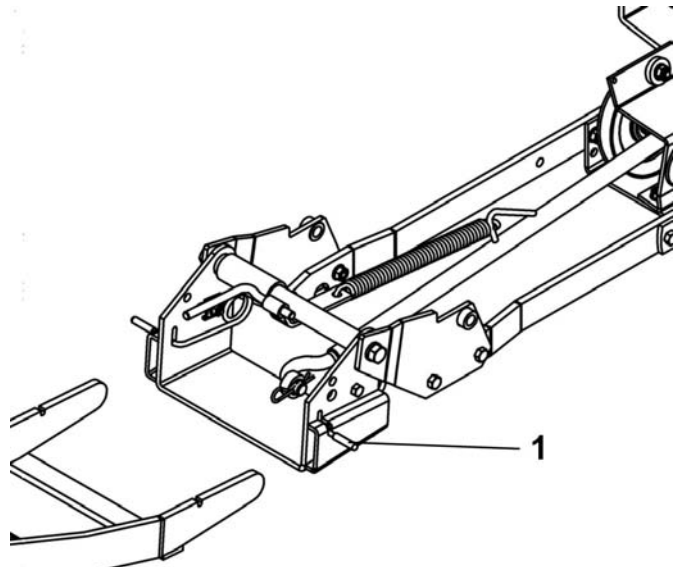

ASSEMBLY

Insert the handle (item 1) into the support (item 2) as shown.

Install the handle (item 1) on the control rod (item 3) as shown and secure with a 2.5 mm hair pin (item 4).

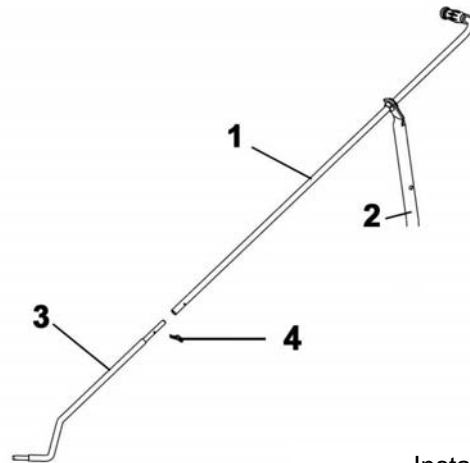

Install handle

Reinstall the helper spring as originally installed.

Raise the blade. Pull up the tension arm (item 1). This spring helps to lift the blade with little effort.

Note: If the blade does not scrape enough, remove the helper spring.

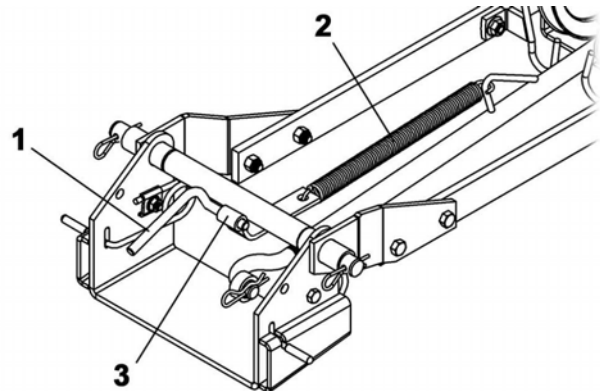

Apply tension on helper spring

VERIFY TIRE PRESSURE:

Attachments should raise 3" to 4" above the ground (no more, no less) if not, check and adjust tractor tire pressure as follows:

Front tires: 14-15 psi
Back tires: 7-8 psi

Tire pressure must be even on both sides of the tractor.

MAINTENANCE & DISMOUNTING

9

WARNING

9

TO PREVENT INJURIES:

Stop the motor.

Apply parking brakes.

Remove the ignition key.

Disconnect the wire from the spark plug(s) and keep away from spark plug(s) to prevent accidental starting.

MAINTENANCE

- Check mounting bolts at frequent intervals for proper tightness to be sure the equipment is in safe working condition.
- Apply oil at all pivot points.

BELT ADJUSTMENT

When the attachment is on the ground, the tension arm should be vertical or at approximately 90° with the subframe's flat bars.

If it is not vertical, release the tension on the belt by moving the arm (item 1) towards the back. Adjust the tension on the belt by moving the left hand side adjustable pulley (item 3). To adjust, loosen the bolt located in the middle of the pulley and slide the pulley in the slot. Tighten the bolt. Apply tension on the belt by moving the tension arm towards the front. Verify the adjustment. Make sure the tension arm (item 2) is approximately at 90° with the subframe's flat bars and blocked in the hole with a 3 mm hair pin.

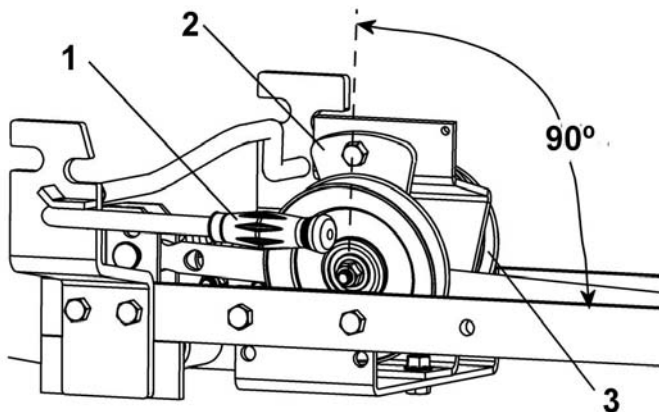

SUBFRAME DISMOUNTING

See Attachment Owner's manual (Snowblower, Rotary Broom, Utility Blade) for attachment dismounting instructions.

- Remove the rear counterweight.
- Release tension on the belt by moving the tension arm towards the back.

9

CAUTION

9

TO PREVENT INJURIES:

Always raise the attachment to reduce the tension on the spring before applying or releasing tension on the helper spring. Firmly hold the handle when you release the tension because the arm will kick back due to the tension on the spring.

- Unhook the spring
- Remove the two pins that hold the back of the subframe.
- Remove the two pins that hold the front of the subframe.
- Unhook and lower carefully the subframe.
- Carefully pull out the subframe by middle of the tractor from the left side between the front and rear wheels.

END OF SEASON STORAGE

- Clean and repaint all parts from which the paint has worn.
- Apply oil at all pivot points.
- Inspect and replace all defective parts before next season.

TORQUE SPECIFICATION TABLE

GENERAL TORQUE SPECIFICATION TABLE USE THE FOLLOWING TORQUES WHEN SPECIAL TORQUES ARE NOT GIVEN

NOTE: These values apply to fasteners as received from supplier, dry or when lubricated with normal oil. They do not apply if special graphited or moly disulphide greases or other extreme pressure lubricants are used. This applies to both UNF and UNC threads.

SEE Grade No.		2				5				8 *			
BOLT HEAD IDENTIFICATION MARKS AS PER GRADE NOTE MANUFACTURING MARKS WILL VARY		TORQUE				TORQUE				TORQUE			
BOLT SIZE		POUNDS FEET		NEWTON-METERS		POUNDS FEET		NEWTON-METERS		POUNDS FEET		NEWTON-METERS	
Inches	Millimetre	Min.	Max.	Min.	Max.	Min.	Max.	Min.	Max.	Min.	Max.	Min.	Max.
1/4"	6.35	5	6	6.8	8.13	9	11	12.2	14.9	12	15	16.3	30.3
5/16"	7.94	10	12	13.6	16.3	17	20.5	23.1	27.8	24	29	32.5	39.3
3/8"	9.53	20	23	27.1	31.2	35	42	47.5	57	45	54	61	73.2
7/16"	11.11	30	35	40.7	47.4	54	64	73.2	86.8	70	84	94.9	113.9
1/2"	12.7	45	52	61	70.5	80	96	108.5	130.2	110	132	149.2	179
9/16"	14.29	65	75	88.1	101.6	110	132	149.2	179	160	192	217	260.4
5/8"	15.88	95	105	128.7	142.3	150	180	203.4	244.1	220	264	298.3	358
3/4"	19.05	150	185	203.3	250.7	270	324	366.1	439.3	380	456	515.3	618.3
7/8"	22.23	160	200	216.8	271	400	480	542.4	650.9	600	720	813.6	976.3
1"	25.4	250	300	338.8	406.5	580	696	786.5	943.8	900	1080	1220.4	1464.5

*Thick nuts must be used with grade 8 bolts

METRIC BOLT TORQUE SPECIFICATIONS							
		COARSE THREAD			FINE THREAD		
Size Screw	Grade No.	Pitch (mm)	Pounds Feet	Newton-Meters	Pitch (mm)	Pounds Feet	Newton-Meters
M6	4T	1.00	3.6 - 5.8	4.9 - 7.9	-	-	-
	7T		5.8 - 9.4	7.9 - 12.7		-	-
	8T		7.2 - 10	9.8 - 13.6		-	-
M8	4T	1.25	7.2 - 14	9.8 - 19	1.00	12 - 17	16.3 - 23
	7T		17 - 22	23 - 29.8		19 - 27	25.7 - 36.6
	8T		20 - 26	27.1 - 35.2		22 - 31	29.8 - 42
M10	4T	1.50	20 - 25	27.1 - 33.9	1.25	20 - 29	27.1 - 39.3
	7T		34 - 40	46.1 - 54.2		35 - 47	47.4 - 63.7
	8T		38 - 46	51.5 - 62.3		40 - 52	54.2 - 70.5
M12	4T	1.75	28 - 34	37.9 - 46.1	1.25	31 - 41	42 - 55.6
	7T		51 - 59	69.1 - 79.9		56 - 68	75.9 - 92.1
	8T		57 - 66	77.2 - 89.4		62 - 75	84 - 101.6
M14	4T	2.00	49 - 56	66.4 - 75.9	1.50	52 - 64	70.5 - 86.7
	7T		81 - 93	109.8 - 126		90 - 106	122 - 143.6
	8T		96 - 109	130.1 - 147.7		107 - 124	145 - 168
M16	4T	2.00	67 - 77	90.8 - 104.3	1.50	69 - 83	93.5 - 112.5
	7T		116 - 130	157.2 - 176.2		120 - 138	162.6 - 187
	8T		129 - 145	174.8 - 196.5		140 - 158	189.7 - 214.1
M18	4T	2.00	88 - 100	119.2 - 136	1.50	100 - 117	136 - 158.5
	7T		150 - 168	203.3 - 227.6		177 - 199	239.8 - 269.6
	8T		175 - 194	237.1 - 262.9		202 - 231	273.7 - 313
M20	4T	2.50	108 - 130	146.3 - 176.2	1.50	132 - 150	178.9 - 203.3
	7T		186 - 205	252 - 277.8		206 - 242	279.1 - 327.9
	8T		213 - 249	288.6 - 337.4		246 - 289	333.3 - 391.6

PARTS BREAKDOWN / NOMENCLATURE DES PIÈCES PUSH FRAME / CHÂSSIS DE POUSSÉE

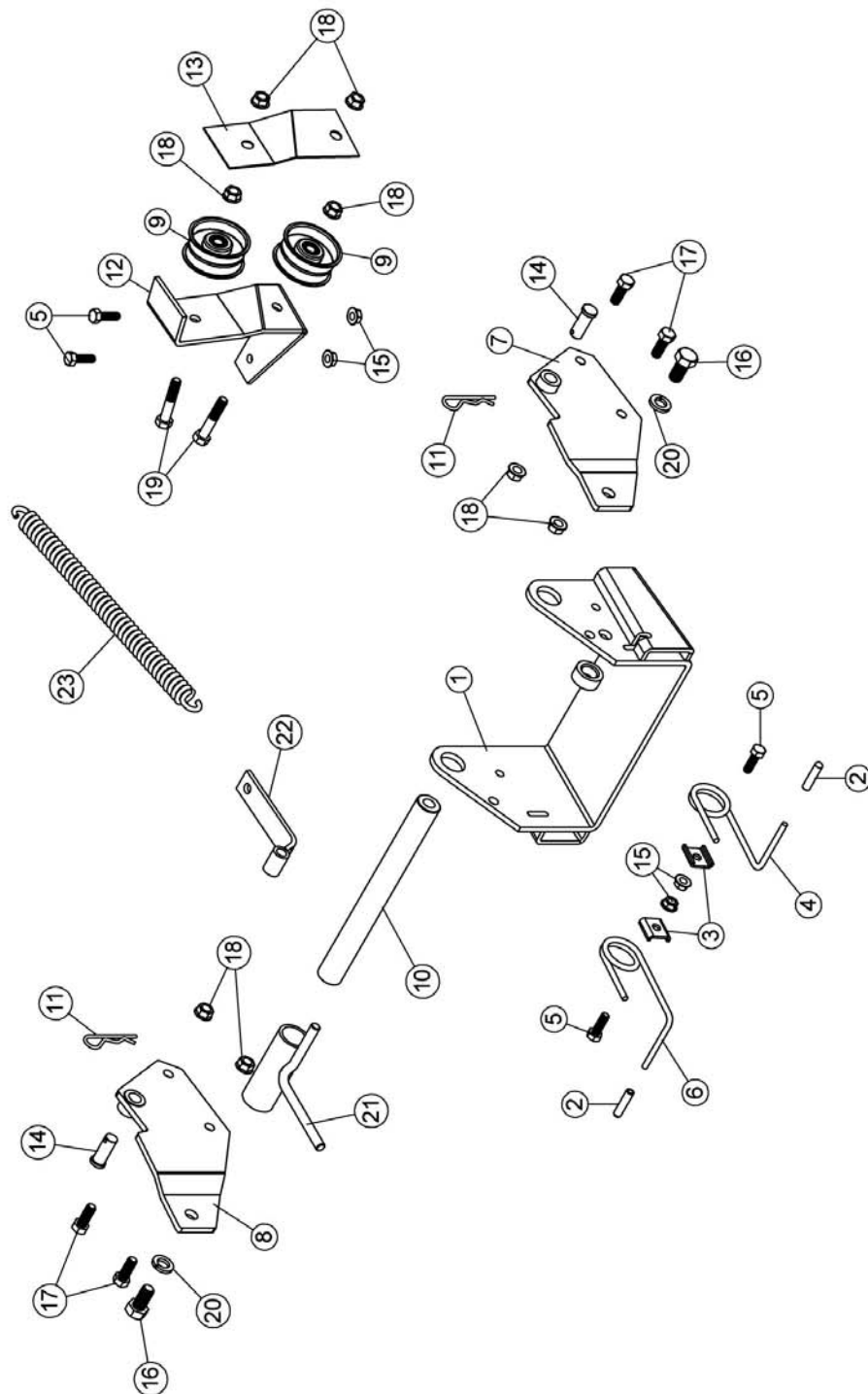

PARTS LIST / LISTE DES PIÈCES

Ref. Réf.	English description	Description française	Qty. Qté.	Part # Pièce #
1	Pivot support	Support de pivot	1	102655
2	Handgrip	Poignée	2	102248
3	Spring bracket	Fixation du ressort	2	102210
4	Left spring lock	Ressort de barrure gauche	1	102208
5	Hex. bolt 5/16" n.c. x 1"	Boulon hex. 5/16" n.c. x 1"	4	O/L
6	Right spring lock	Ressort de barrure droit	1	102209
7	Left front support	Support avant gauche	1	103078
8	Right front support	Support avant droit	1	103079
9	Flat pulley	Poulie plate	2	102057
10	Pin	Goupille	1	102258
11	Hair pin 3mm	Goupille à ressort 3mm	2	102617
12	Double pulley support	Support de poulie double	1	103284
13	Idler guard	Garde-poulie	1	103285
14	Pin	Goupille	2	103070
15	Flange nut 5/16" n.c.	Écrou à bride 5/16" n.c.	4	O/L
16	Hex. bolt 1/2" n.c. x 1"	Boulon Hex. 1/2" n.c. x 1"	2	O/L
17	Hex. bolt 3/8" n.c. x 1"	Boulon hex. 3/8" n.c. x 1"	4	O/L
18	Flange nut 3/8" n.c.	Écrou à bride 3/8" n.c.	8	O/L
19	Hex. bolt 3/8" n.c. x 2"	Boulon hex. 3/8" n.c. x 2"	2	O/L
20	Lock washer 1/2"	Rondelle de blocage 1/2"	2	O/L
21	Tension arm	Bras de tension	1	103920
22	Spring link	Lien de ressort	1	103281
23	Spring	Ressort	1	103073

O/L = Obtain locally/obtenir localement

PARTS BREAKDOWN / NOMENCLATURE DES PIÈCES SUBFRAME / SOUS-CHÂSSIS



PARTS LIST / LISTE DES PIÈCES

Ref. Réf.	English description	Description française	Qty. Qté.	Part # Pièce #
1	Right subframe flat bar	Fer plat droit du sous-châssis	1	102263
2	Left subframe flat bar	Fer plat gauche du sous-châssis	1	102262
3	Push tube	Tube de poussée	1	103922
4	Support plate	Plaque de support	1	103646
5	Spring 1 1/8"	Ressort 1 1/8"	1	102004
6	Flange nut 3/8" n.c.	Écrou à bride 3/8" n.c.	13	O/L
7	Flat washer 7/16" hole	Rondelle plate 7/16" trou	8	O/L
8	Flange washer	Rondelle à bride	2	102081
9	Pulley support	Support de poulie	1	102082
10	Carriage bolt 3/8" n.c. x 1-1/2"	Boulon à carrosserie 3/8" n.c. x 1 1/2"	1	O/L
11	Hex. bolt 3/8" n.c. x 2 1/2"	Boulon hex 3/8" n.c. x 2 1/2"	3	O/L
12	Hex. bolt 3/8" n.c. x 1"	Boulon hex. 3/8" n.c. x 1"	4	O/L
13	Hex. bolt 7/16" n.c. x 1"	Boulon hex. 7/16" n.c. x 1"	1	O/L
14	Lock washer 7/16"	Rondelle de blocage 7/16"	1	O/L
15	Hex. nut 7/16" n.c.	Écrou hex. 7/16" n.c.	1	O/L
16	Cotter pin 5/32" x 1"	Goupille fendue 5/32" x 1"	1	O/L
17	Hair pin 3mm	Goupille à ressort 3mm	3	102617
18	Pin	Goupille	1	102079
19	Hex. bolt 3/8" n.c. x 1 1/4"	Boulon hex. 3/8" n.c. x 1 1/4"	6	O/L
20	V Pulley	Poulie en "V"	2	102086
21	Idler arm	Bras de tension	1	103074
22	Handgrip	Poignée	1	102062
23	Right rear support	Support arrière droit	1	103925
24	Left rear support	Support arrière gauche	1	103926
25	Idler arm	Bras de poulie	1	102089
26	Mounting pin	Goupille de montage	2	102257
27	Adjusting rod	Tige d'ajustement	1	102653
28	Freeway bearing	Roulement utilitaire	2	102075
29	Right spacer	Douille d'espacement droite	1	104071

O/L = Obtain locally/obtenir localement

PARTS LIST / LISTE DES PIÈCES

Ref. Réf.	English description	Description française	Qty. Qté.	Part # Pièce #
30	Hex. bolt 5/8" n.c. x 4"	Boulon hex. 5/8" n.c. x 4"	1	O/L
31	Flat washer 11/16" hole	Rondelle plate 11/16" trou	2	O/L
32	Lever lock	Barrure de levier	2	102078
33	Lock washer 5/8"	Rondelle de blocage 5/8"	1	O/L
34	Hex. nut 5/8" n.c.	Écrou hex. 5/8" n.c.	1	O/L
35	Lift arm extension	Extension de bras de relevage	1	102406
36	Flange nut 5/16" n.c.	Écrou à bride 5/16" n.c.	2	O/L
37	Hex. bolt 5/16" n.c. x 3/4"	Boulon hex. 5/16" n.c. x 3/4"	2	O/L
38	Lift arm	Bras de relevage	1	103923
39	Hex. bolt 3/8" n.c. x 3/4"	Boulon hex. 3/8" n.c. x 3/4"	1	O/L
40	Handle support	Support de manivelle	1	102243
41	Plastic grommet	Oeillet de plastique	1	102063
42	V-Belt B-120	Courroie en V B-120	1	102048
43	Handgrip	Poignée de plastique	1	102025
44	Lift support	Support de relevage	2	103924
45	Lift lever	Levier de relevage	1	103287
46	Stover lock nut 3/8" n.c.	Écrou de blocage 3/8" n.c.	2	O/L
47	Left spacer	Douille d'espacement gauche	1	104068

O/L = Obtain locally/obtenir localement

ATTACHMENTS

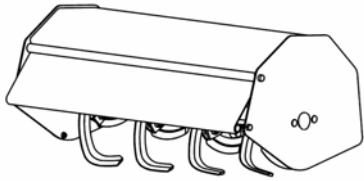

ROTARY TILLER #700312

Mounts to the rear of lawn & garden tractors 14 to 25 HP. Comes complete with drive & manual lift mechanisms & mounting hardware.

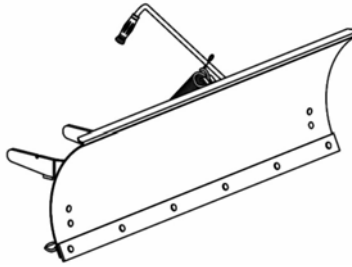

UTILITY BLADE #700266

Mounts on the same subframe as the snowblower & rotary broom.

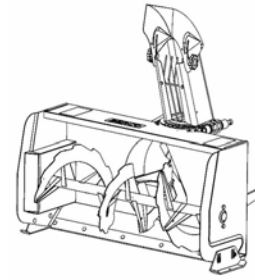

SNOWBLOWER

#700210 40"
#700211 44"

Fits on same subframe as rotary broom and utility blade.

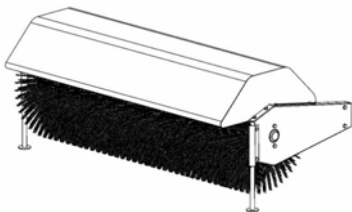

ROTARY BROOM

#700286 with nylon brush
/#700316 with polypropylene brush.

Fits on same subframe as snowblower & utility blade. Requires an adaptor.

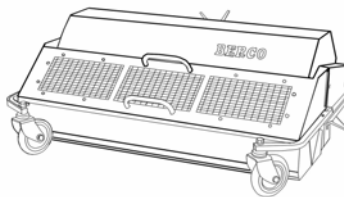

DEBRIS COLLECTOR #700235

Quickly & easily fitted on front of rotary brooms #700286 and #700316. Collects debris in container with easy manual dumping. Reduces dust.

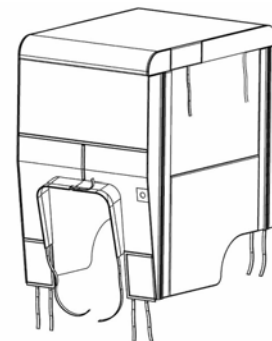

TRACTOR WINTER CAB #700271

Universal type fits on a wide variety of lawn and garden tractors.

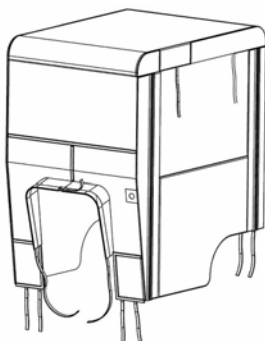

TRACTOR SCREEN CAB #700313

Universal type fits on a wide variety of lawn and garden tractors.

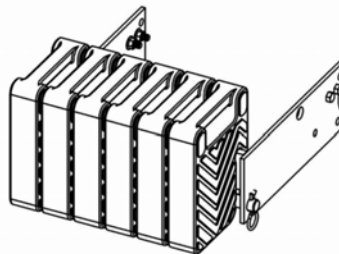

COUNTERWEIGHT

#700240 Universal rear weights
#700246 Rear weights Electrolux
Required for safety and traction. Counterbalances weight of attachment.

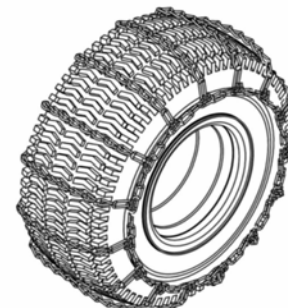

TIRE CHAINS

Two link spacing. Required for traction and safety.
Pkg. of 2