



OWNER'S MANUAL
Model Number

700219-2



BERCO
Subframe
for
JOHN DEERE

SERIES LX255, 266, 277, 277AWS, 279, 288, LX172, 173, 176, 178, 188
SERIES GT225, 235, 242, 245, 262, 275, 325, 335, 345, 355, GX325, 335, 345, 355

SABRE
SERIES GT1842, 1848, 2048, 2148, 2254, 2354, 2554 (GH or HV)
Tractors

- * ASSEMBLY
- * OPERATION

- * REPAIR PARTS
- * MAINTENANCE

CAUTION:

**READ & FOLLOW ALL SAFETY RULES & INSTRUCTIONS
BEFORE OPERATING YOUR EQUIPMENT**

WARRANTY

LIMITED ONE YEAR ON BERCO TRACTOR ATTACHMENTS

For one year from date of purchase, Bercomac Limitée will repair or replace free of charge at Bercomac's option, any parts which are defective as a result of defective materials or faulty workmanship.

COMMERCIAL OR RENTAL USE:

Warranty on Berco attachments used for commercial or rental purposes is limited to 90 days.

This warranty does NOT cover:

- * Wear items, such as shear pins and belts.
- * Repairs due to customer abuse or neglect.
- * Pre-delivery set-up.
- * In home service.

Warranty service is available by returning the "Berco" attachment to the authorized dealer.

BERCOMAC Limitée
46 Fortin N, Adstock, Québec, Canada, G0N 1S0

TABLE OF CONTENTS

	PAGE
INTRODUCTION	2
SAFETY PRECAUTIONS	3
ASSEMBLY	
Step 1: Subframe Preparation	5
John Deere models: LX 255, 266, 277, 277AWS, 279, 288 and GT 225, 235 245	
Subframe Installation	7
Subframe Preparation	8
John Deere models: LX 172, 173, 176, 178, 188, and GT 242, 262, 275	
Subframe Installation	10
Subframe Preparation	11
John Deere models: 325, 335, 345, 355 and GX 325, 335, 345, 355	
Subframe Installation	13
Subframe Preparation	14
Sabre models: GT1842, 1848, 2048, 2148, 2254, 2354, 2554 (GH or HV)	
Subframe Installation	16
Step 2: Snowblower Installation	17
Rotary Broom Installation	20
Utility Blade Installation	23
MAINTENANCE & DISMOUNTING	
Maintenance	24
Belt Adjustment	24
Subframe Dismounting	24
End of Season Storage	24
TORQUE SPECIFICATION TABLE	25
PARTS BREAKDOWN AND LISTS	
Push frame	26
Subframe	28
OPTIONS	31
TROUBLESHOOTING	
See attachment owner's manual for this section. (Snowblower, Utility Blade, Rotary Broom)	

INTRODUCTION

TO THE PURCHASER

This new attachment was carefully designed to give years of dependable service. This manual has been provided to assist in the safe operation and servicing of your attachment.

NOTE: All photographs and illustrations in the manual may not necessarily depict the actual models or attachment, but are intended for reference only and are based on the latest product information available at the time of publication.

Familiarize yourself fully with the safety recommendations and operating procedures before putting the machine to use. Carefully read, understand and follow these recommendations and insist that they be followed by those who will use this attachment.

9

THIS SAFETY ALERT SYMBOL IDENTIFIES AN IMPORTANT SAFETY MESSAGE IN THIS MANUAL THAT HELPS YOU AND OTHERS AVOID PERSONAL INJURY OR EVEN DEATH. DANGER, WARNING, AND CAUTION ARE SIGNAL WORDS USED TO IDENTIFY THE LEVEL OF HAZARD. HOWEVER, REGARDLESS OF THE HAZARD, BE EXTREMELY CAREFUL.

DANGER: Signals an extreme hazard that will cause serious injury or death if recommended precautions are not followed.

WARNING: Signals a hazard that may cause serious injury or death if the recommended precautions are not followed.

CAUTION: Signals a hazard that may cause minor or moderate injury if the recommended precautions are not followed.

Record your attachment serial number and purchase date in the section reserved below (there is no serial number on the subframe). Your dealer requires this information to give you prompt, efficient service when ordering replacement parts. Use only genuine parts when replacements are required.

If warranty repairs are required please present this registration booklet and original sales invoice to your selling dealer for warranty service.

This manual should be kept for future reference.

SERIAL NUMBER : _____

PURCHASE DATE : _____

In this manual, right and left sides are determined by sitting on the tractor seat facing forward.

In this manual, "attachment" means accessories that you install on the tractor, such as, snowblower, rotary broom, blade, rotary tiller, cab, subframe, etc...

SAFETY PRECAUTIONS

Careful operation is your best insurance against an accident. Read this section carefully before operating the tractor and attachment. All operators, no matter how experienced they may be, should read this and other manuals related to the tractor and attachments before operating. It is the owner's legal obligation to instruct all operators in safe operation.

TRAINING

9 This symbol, "Safety Alert Symbol", is used throughout this manual and on the attachment safety labels to warn of the possibility of personal injury. Please take special care in reading and understanding the safety precautions before operating the attachment or the tractor.

1. Read this Owner's Manual carefully. Be thoroughly familiar with the controls and proper use of the attachment. Know how to stop the unit and disengage the controls quickly.
2. Never allow children to operate attachment. Never allow adults to operate attachment without proper instructions.
3. No one should operate the unit while intoxicated or while taking medication that impairs the senses or reactions.
4. Keep the area of operation clear of all persons, particularly small children and pets.

PREPARATION

1. Disengage all clutches and shift into neutral before starting engine.
2. Handle fuel with care, it is highly flammable.
 - a) Use approved fuel container.
 - b) Never add fuel to a running engine or hot engine
 - c) Fill fuel tank outdoors with extreme care. Never fill fuel tank indoors.
 - d) Replace fuel cap securely and wipe up spilled fuel.
3. Never attempt to make any adjustments while engine is running (except where specifically recommended by manufacturer).

4. Always wear safety glasses or eye shields during operation or while performing an adjustment or repairs to protect eyes from foreign objects that may be thrown from the machine.

OPERATION

1. Do not run engine indoors except when starting engine and transporting attachment, in or out of building. Do not operate or let motor run in a storage area without ventilation because gas contains carbon monoxide which is odourless, colourless and can cause death.
2. Do not carry passengers on attachment or tractor.
3. Take all possible precautions when leaving the machine unattended. Lower the attachment, shift into neutral, set the parking brake, stop the engine and remove the key. Wait for all moving parts to stop.
4. You must use manufacturer approved rear counterweights, minimum 100 lbs., for better traction and safety at all times when you have an attachment installed in front.
5. Never operate the attachment without good visibility or light.

SAFETY PRECAUTIONS

MAINTENANCE AND STORAGE

1. Check shear bolts, mounting bolts, etc..., at frequent intervals for proper tightness to be sure attachment is in safe working condition.
2. Never store the machine with fuel in the tank inside a building where ignition sources are present, such as hot water tanks, space heaters, clothes dryers and the like. Allow engine to cool before storing in any enclosure.
3. Maintain or replace safety and instructions labels, as necessary.

WHENEVER YOU SEE THIS SYMBOL

9

IT MEANS:

WARNING!

BECOME ALERT !

YOUR SAFETY IS INVOLVED!

9

WARNING

9

FOR YOUR SECURITY:

Read the attachment owner's manual for safety precautions and rules.

Follow the assembly and operation instructions.

ASSEMBLY

STEP 1

SUBFRAME PREPARATION FOR THE JOHN DEERE TRACTORS

MODELS: LX 255, 266, 277, 277AWS, 279, 288 and
GT 225, 235 245

IMPORTANT: TORQUE ALL BOLTS ACCORDING TO TORQUE SPECIFICATION TABLE (SEE TABLE OF CONTENTS) WHEN STATED: TIGHTEN FIRMLY. REFER TO PARTS BREAKDOWN SECTION FOR PARTS IDENTIFICATION.

NOTE: The mower deck must be removed to install the subframe.

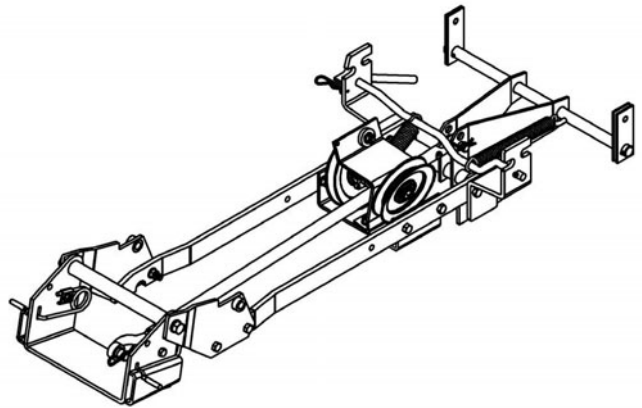

View once unpacked

Remove the bolt that holds the left hand side mower lift arm (item 1). Reinstall the lift arm by inserting as shown the mounting pin (item 2), original sleeve (item 4) and flat washer (item 3) from the tractor. Secure with the original nut inside the tractor frame. Do the same thing on the right side. Tighten firmly.

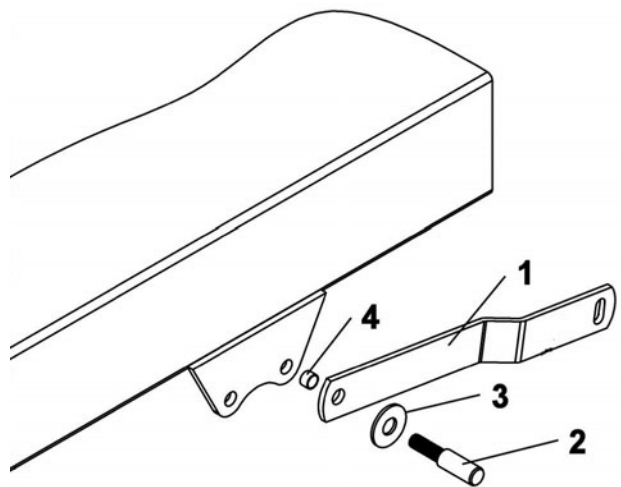

Install the mounting pins

ASSEMBLY

Unhook the helper spring (item 6).

Install the handle support (item 1) on the left hand side with a $3/8 \times 1\ 1/4$ " hex bolt (item 2) and flange nut already in place, a $3/8 \times 1$ " hex bolt (item 3) and flange nut.

Tighten firmly.

Insert the plastic grommet (item 4) in the handle support.

Install the handgrip (item 5) as shown.

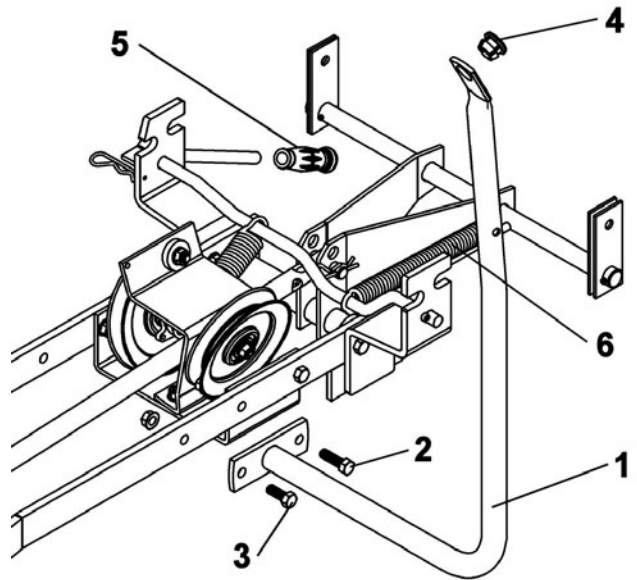

Install handle support

Remove the hair pin (item 1) and unhook the adjusting rod (item 2) from the pivot support.

NOTE: In order to facilitate the subframe installation, rotate the pivot support towards the front.

Make sure that the other end of the push tube (item 3) is secured in the second hole (item 5) with a pin (item 4) and in the bottom hole (item 6) of the lift lever (item 7).

Adjust the overall length of the push tube to 33.50" by screwing or unscrewing the adjusting rod (item 2).

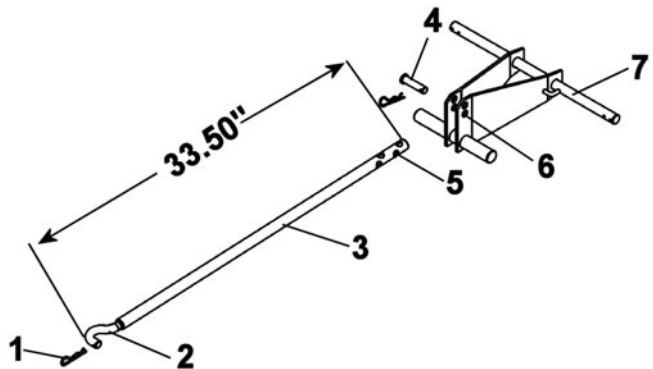

Adjust the length of push tube

ASSEMBLY

SUBFRAME INSTALLATION:

9

WARNING

9

TO PREVENT INJURIES:

Stop the motor.

Apply parking brake.

Remove the ignition key.

Disconnect the wire from the spark plug(s) and keep away from spark plug(s) to prevent accidental starting.

Slide the subframe under the tractor between the front and back wheels on the left side.

Lift the back part of the subframe and hook the supports (item 1) by the back slot (as shown) on the mounting pins (item 2).

Lift the front part of the subframe between the tractor supports (item 3).

Secure in place in the square holes (item 7) with two 0.50 x 1.25" pins (item 4) and two 3 mm hair pins (item 5).

NOTE: If the holes are not aligned, loosen the supports, install the pins and retighten the support bolts tightly.

If the tractor supports (item 3) are too narrow, loosen the heat shield bolts.

Reinstall the adjusting rod (item 6) and secure in place with a 3 mm hair pin.

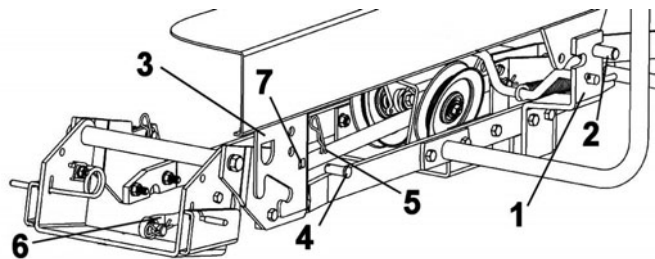

Install the subframe

Adjust the mower's cutting height knob to "0". Push the tractor's lift arm completely towards the front in order to lower the mower's suspension arms.

Secure the lift lever (item 1) as shown to the mower lift arm with a 0.38 x 1.00 pin (item 2) and a 2 mm hair pin (item 3).

Do the same operation on the other side.

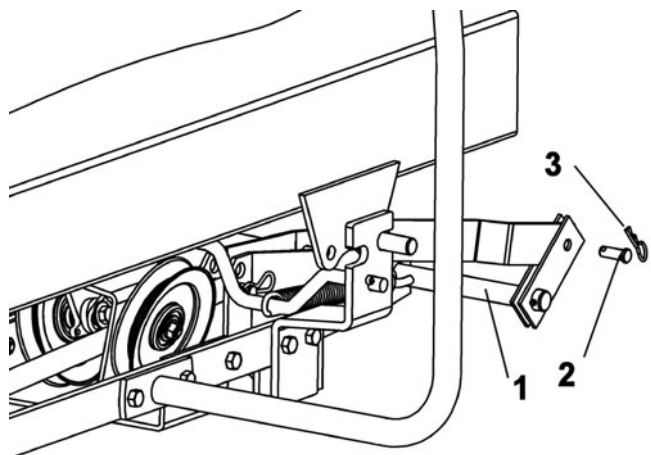

Install the lift lever

ASSEMBLY

SUBFRAME PREPARATION FOR THE JOHN DEERE TRACTORS

MODELS: LX 172, 173, 176, 178, 188, and
GT 242, 262, 275

IMPORTANT: TORQUE ALL BOLTS ACCORDING TO TORQUE SPECIFICATION TABLE (SEE TABLE OF CONTENTS) WHEN STATED: TIGHTEN FIRMLY. REFER TO PARTS BREAKDOWN SECTION FOR PARTS IDENTIFICATION.

NOTE: The mower deck must be removed to install the subframe.

Replace the front supports (item 1 & 2) by the other supports (items 3 & 4) that are in the box. Reinstall in the same fashion as the supports you removed, the bend towards the outside. Insert the bolts (item 5) in the holes as shown. Tighten the bolts firmly.

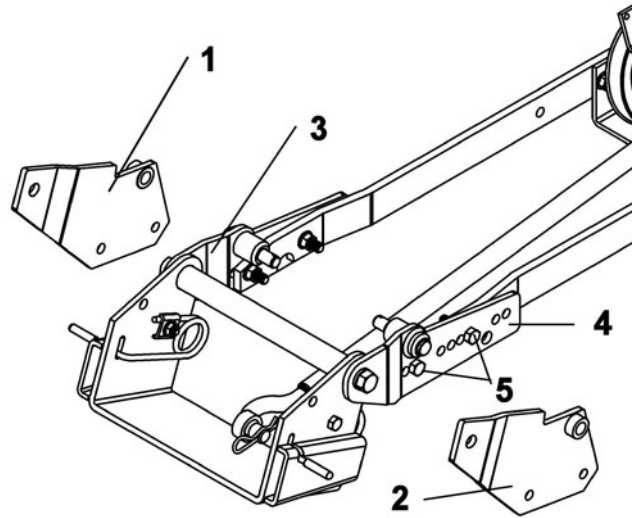

Replace the front supports

Remove the bolt that holds the left hand side mower lift arm (item 1). Reinstall the lift arm by inserting as shown the mounting pin (item 2), original sleeve (item 4) and flat washer (item 3) from the tractor. Secure with the original nut inside the tractor frame. Do the same thing on the right side. Tighten firmly.

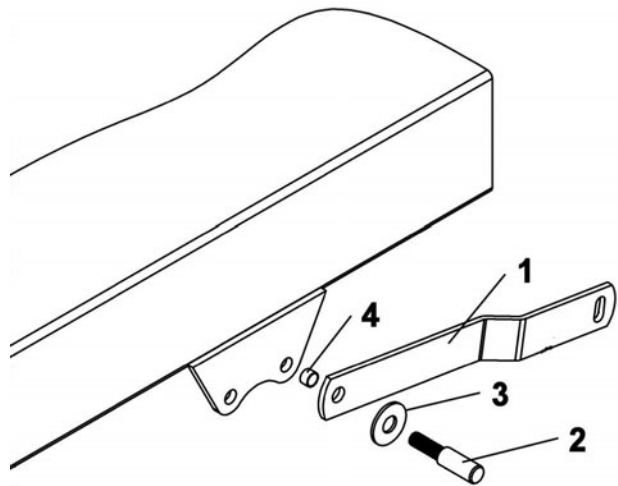

Install mounting pins

ASSEMBLY

Remove the helper spring (item 6).

Install the handle support (item 1) on the left hand side with a $3/8 \times 1 \ 1/4$ " hex bolt (item 2) and flange nut already in place, a $3/8 \times 1$ " hex bolt (item 3) and flange nut.

Tighten firmly.

Insert the plastic grommet (item 4) in the handle support.

Install the handgrip (item 5) as shown.

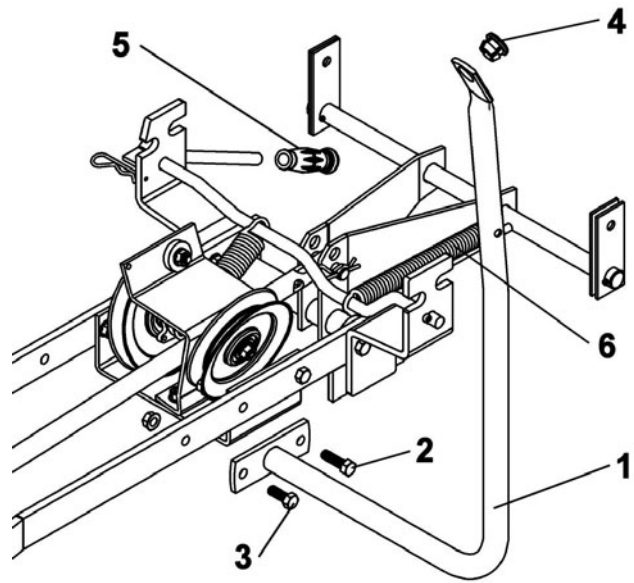

Install handle support

Remove the hair pin (item 1) and unhook the adjusting rod (item 2) from the pivot support.

NOTE: In order to facilitate the subframe installation, rotate the pivot support towards the front.

Make sure that the other end of the push tube (item 3) is secured in the third hole (item 5) with a pin (item 4) and in the bottom hole (item 6) of the lift lever (item 7).

Adjust the overall length of the push tube to 33.81" by screwing or unscrewing the adjusting rod (item 2).

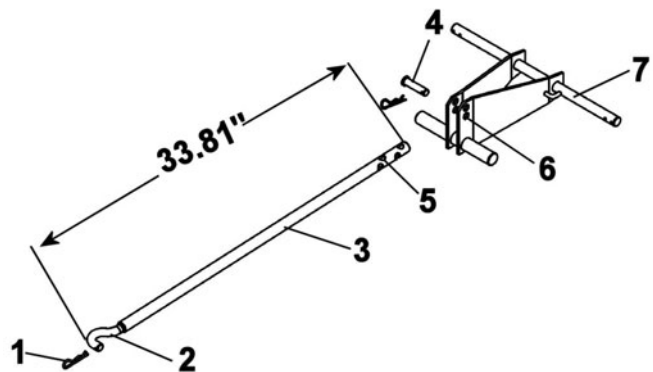

Adjust push tube

ASSEMBLY

SUBFRAME INSTALLATION:

9

WARNING

9

TO PREVENT INJURIES:

Stop the motor.

Apply parking brake.

Remove the ignition key.

Disconnect the wire from the spark plug(s) and keep away from spark plug(s) to prevent accidental starting.

Slide the subframe under the tractor between the front and back wheels on the left side.

Lift the back part of the subframe and hook the supports (item 1) by the front slot (as shown) on the mounting pins (item 2).

Lift the front part of the subframe between the tractor supports (item 3).

Secure in place in the square holes (item 7) with two 0.50 x 2.52" pins (item 4) and two 3 mm hair pins (item 5).

NOTE: If the holes are not aligned, loosen the supports, install the pins and retighten the support bolts tightly.

If the tractor supports (item 3) are too narrow, loosen the heat shield bolts.

Reinstall the adjusting rod (item 6) and secure in place with a 3 mm hair pin.

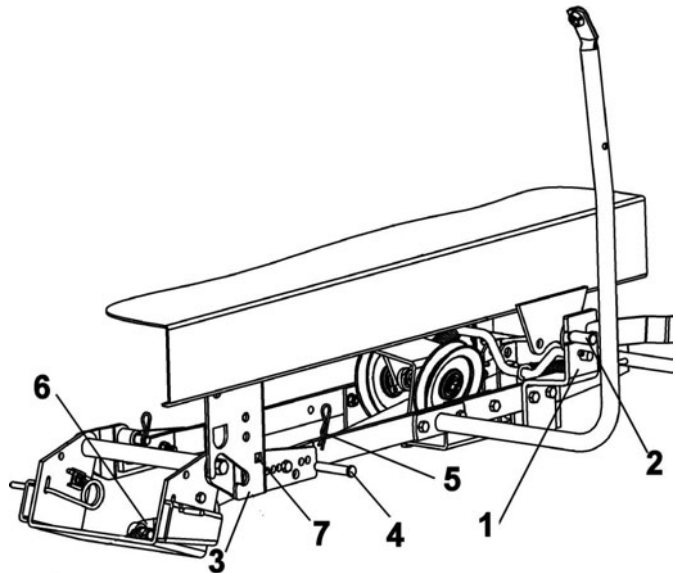

Install subframe

Adjust the mower's cutting height knob to "0". Push the tractor's lift arm completely towards the front in order to lower the mower's suspension arms.

Secure the lift lever (item 1) as shown to the mower lift arm with a 0.38 x 1.00 pin (item 2) and a 2 mm hair pin (item 3).

Do the same operation on the other side.

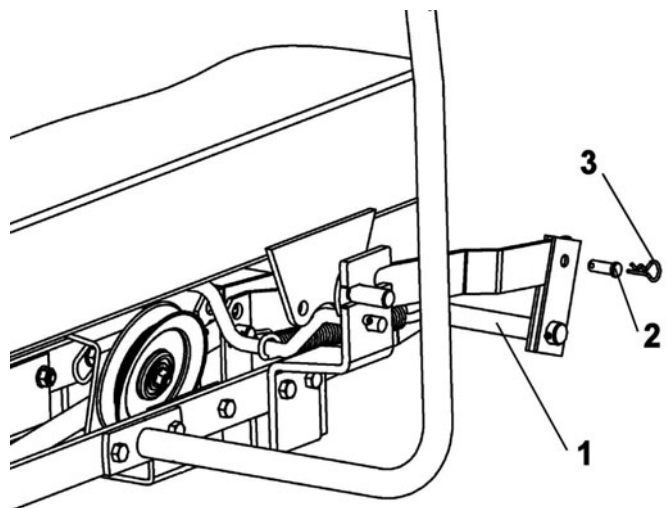

Install lift lever

ASSEMBLY

SUBFRAME PREPARATION FOR THE JOHN DEERE TRACTORS

MODELS: 325, 335, 345, 355
GX 325, 335, 345, 355

IMPORTANT: TORQUE ALL BOLTS ACCORDING TO TORQUE SPECIFICATION TABLE (SEE TABLE OF CONTENTS) WHEN STATED: TIGHTEN FIRMLY. REFER TO PARTS BREAKDOWN SECTION FOR PARTS IDENTIFICATION.

NOTE: The mower deck must be removed to install the subframe.

Replace the front supports (item 1 & 2) by the other supports (items 3 & 4) that are in the box. Reinstall in the same fashion as the supports you removed, but the bend towards the inside and insert a shim (item 5) between the supports and the subframe flat bars. Insert the bolts (item 6) in the holes as shown.

Tighten the bolts firmly.

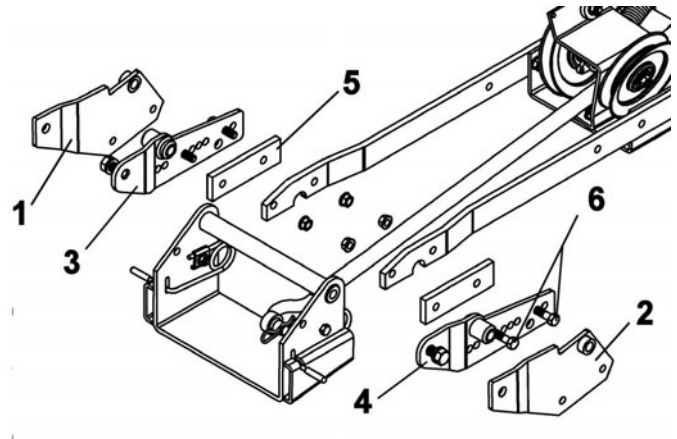

Replace front supports

Remove the bolt that holds the left hand side mower lift arm (item 1). Reinstall the lift arm by inserting as shown the mounting pin (item 2), original sleeve (item 4) and flat washer (item 3) from the tractor.

Secure with the original nut inside the tractor frame.

Do the same thing on the right side.
Tighten firmly.

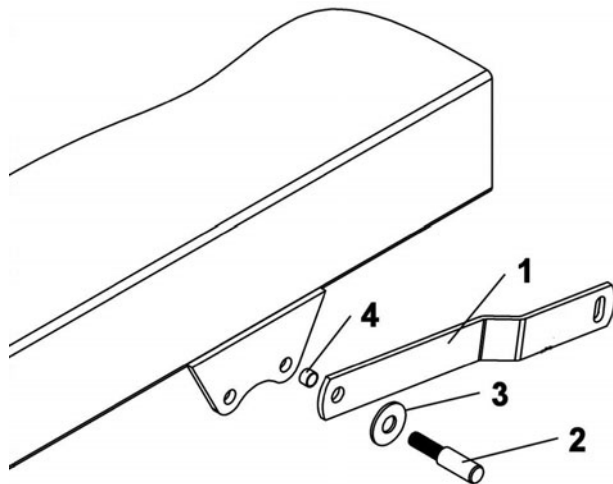

Install handle support

ASSEMBLY

Unhook the helper spring (item 6).

Install the handle support (item 1) on the left hand side with a $3/8 \times 1\ 1/4$ " hex bolt (item 2) and flange nut already in place, a $3/8 \times 1$ " hex bolt (item 3) and flange nut.

Tighten firmly.

Insert the plastic grommet (item 4) in the handle support.

Install the handgrip (item 5) as shown.

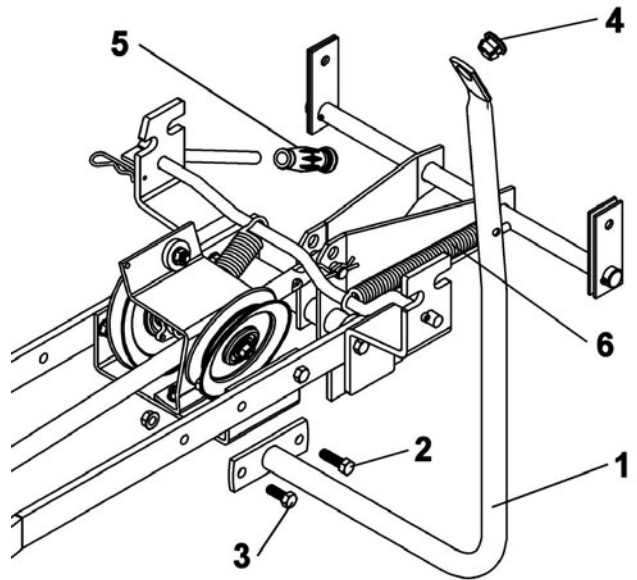

Install handle support

Remove the hair pin (item 1) and unhook the adjusting rod (2) from the pivot support.

NOTE: In order to facilitate the subframe installation, rotate the pivot support towards the front.

Make sure that the other end of the push tube (item 3) is secured in the second hole (item 5) with a pin (item 4) and in the top hole (item 6) of the lift lever (item 7).

Adjust the overall length of the push tube to 33.68" by screwing or unscrewing the adjusting rod (item 2).

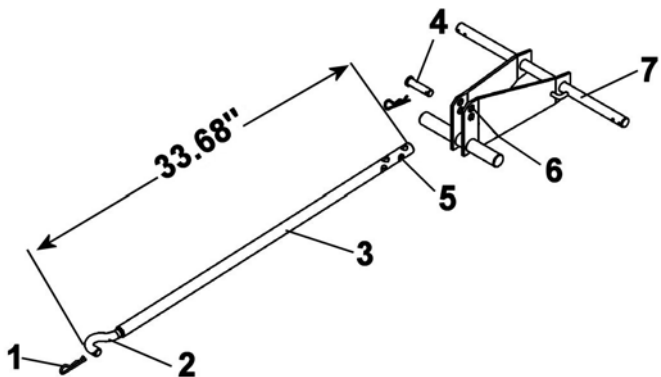

Adjust push tube

ASSEMBLY

SUBFRAME INSTALLATION:

9

WARNING

9

TO PREVENT INJURIES:

Stop the motor.

Apply parking brake.

Remove the ignition key.

Disconnect the wire from the spark plug(s) and keep away from spark plug(s) to prevent accidental starting.

Slide the subframe under the tractor between the front and back wheels on the left side.

Lift the back part of the subframe and hook the supports (item 1), by the front slot (as shown) on the mounting pins (item 2).

Lift the front part of the subframe between the tractor supports (item 3).

Secure in place in the holes (item 7) with two 0.50 x 2.52" pins (item 4) and two 3 mm hair pins (item 5).

NOTE: If the holes are not aligned, loosen the supports, install the pins and retighten the support bolts tightly.

If the tractor supports (item 3) are too narrow, loosen the heat shield bolts.

Reinstall the adjusting rod (item 6) and secure in place with a 3 mm hair pin.

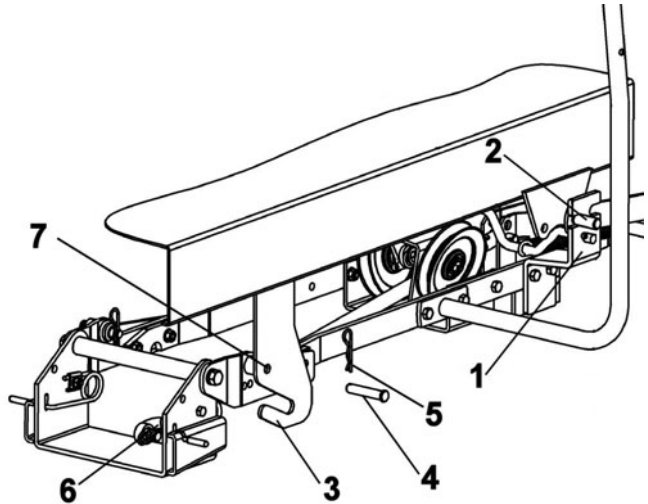

Install subframe

Adjust the mower's cutting height knob to "0". Push the tractor's lift arm or the hydraulic lever completely towards the front in order to lower the mower's suspension arms.

Secure the lift lever (item 1) as shown to the mower lift arm with a pin 0.38 x 1.00 (item 2) and a 2 mm hair pin (item 3).

Do the same operation on the other side.

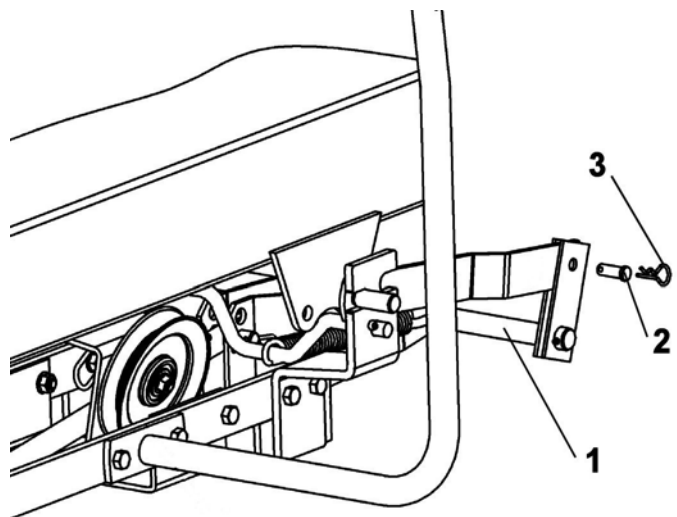

Install lift lever

ASSEMBLY

SUBFRAME PREPARATION FOR THE SABRE TRACTORS

MODELS:GT1842, 1848, 2048, 2148, 2254, 2354, 2554 (GH or HV)

IMPORTANT: TORQUE ALL BOLTS ACCORDING TO TORQUE SPECIFICATION TABLE (SEE TABLE OF CONTENTS) WHEN STATED: TIGHTEN FIRMLY. REFER TO PARTS BREAKDOWN SECTION FOR PARTS IDENTIFICATION.

NOTE: The mower deck must be removed to install the subframe.

Replace the front supports (items 1 & 2) by the other supports (items 3 & 4) that are in the box. Reinstall in the same fashion as the supports you removed, the bend towards the outside.

Insert the bolts (item 5) in the holes as shown. Tighten the bolts firmly.

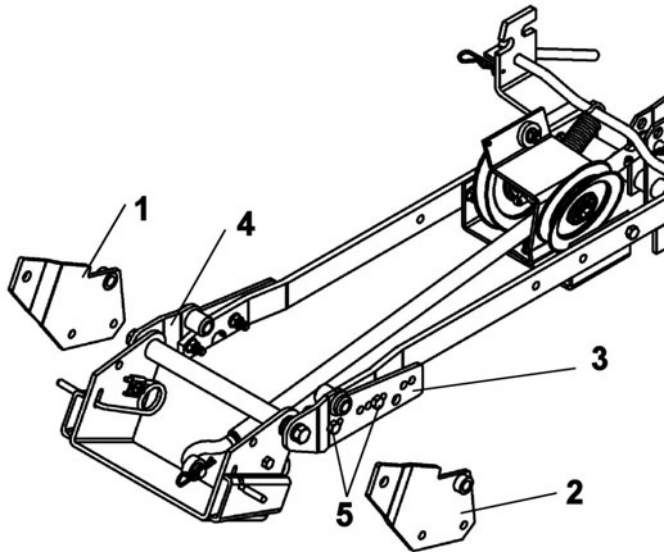

Replace front supports

Remove the bolt that holds the left hand side mower lift arm (item 1). Reinstall the lift arm by inserting as shown the mounting pin (item 2), original sleeve (item 4) and flat washer (item 3) from the tractor.

Secure with the original nut inside the tractor frame.

Do the same thing on the right side.

Tighten firmly.

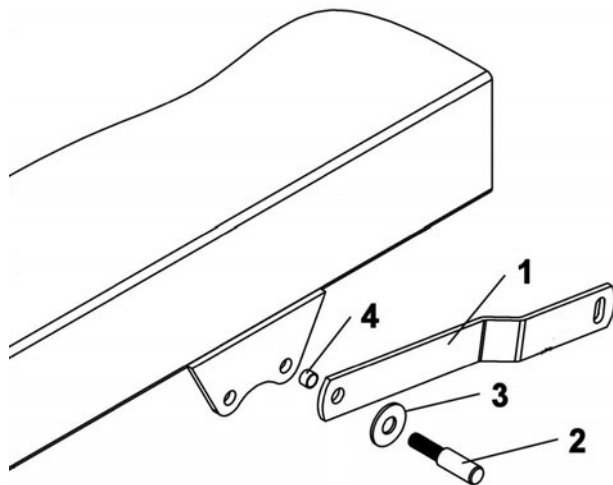

Install mounting pins

ASSEMBLY

Unhook the helper spring (item 6).

Install the handle support (item 1) on the left hand side with a $3/8 \times 1\ 1/4$ " hex bolt (item 2) and flange nut already in place, a $3/8 \times 1$ " hex bolt (item 3) and flange nut.

Tighten firmly.

Insert the plastic grommet (item 4) in the handle support.

Insert the handgrip (item 5) as shown.

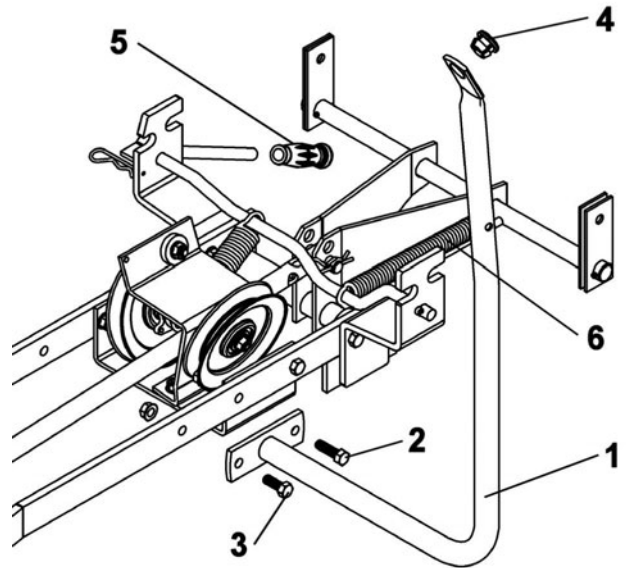

Install handle support

Remove the hair pin (item 1) and unhook the adjusting rod (item 2) from the pivot support.

NOTE: In order to facilitate the subframe installation, rotate the pivot support towards the front.

Make sure that the other end of the push tube (item 3) is secured in the fourth hole (item 5) of the push tube with a pin (item 4) and in the bottom hole (item 6) of the lift lever (item 7).

Adjust the overall length of the push tube to 33.75" by screwing or unscrewing the adjusting rod (item 2).

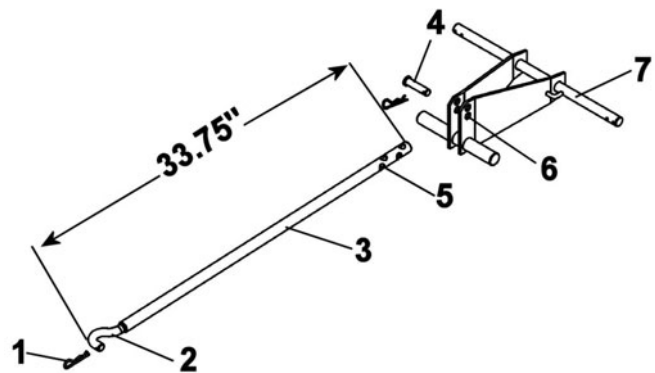

Adjust push tube

ASSEMBLY

SUBFRAME INSTALLATION:

9

WARNING

9

TO PREVENT INJURIES:

Stop the motor.

Apply parking brake.

Remove the ignition key.

Disconnect the wire from the spark plug(s) and keep away from spark plug(s) to prevent accidental starting.

Slide the subframe under the tractor between the front and back wheels on the left side.

Lift the back part of the subframe and hook the supports (item 1), by the front slot (as shown) on the mounting pins (item 2).

Lift the front part of the subframe between the tractor supports (item 3).

Secure in place in the square holes (item 7) with two 0.50 x 2.52" pins (item 4) and two 3 mm hair pins (item 5).

NOTE: If the holes are not aligned, loosen the supports, install the pins and retighten the support bolts tightly.

If the tractor supports (item 3) are too narrow, loosen the heat shield bolts.

Reinstall the adjusting rod (item 6) and secure in place with a 3 mm hair pin.

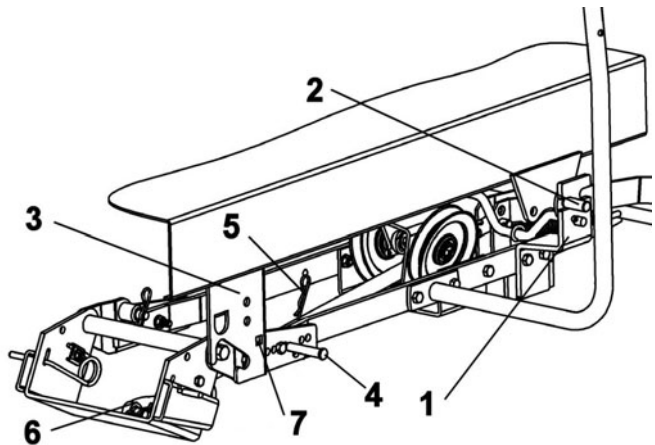

Install subframe

Adjust the mower's cutting height knob to "0". Push the tractor's lift arm completely towards the front in order to lower the mower's suspension arms.

Secure the lift lever (item 1) as shown to the mower lift arm with a 0.38 x 1.00 pin (item 2) and a 2 mm hair pin (item 3).

Do the same operation on the other side.

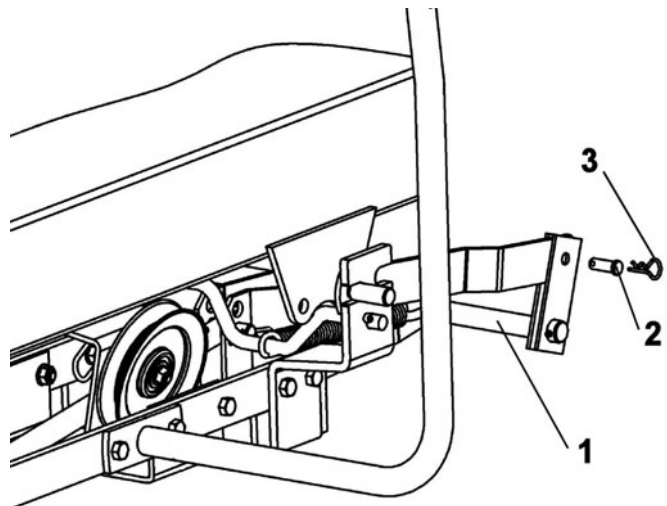

Install lift lever

ASSEMBLY

STEP 2

SNOWBLOWER INSTALLATION:

Refer to snowblower owner's manual, parts breakdown section for parts identification.

9

WARNING

9

FOR YOUR SECURITY:

Read the snowblower owner's manual for safety precautions and rules.

Follow the assembly and operation instructions.

9

WARNING

9

TO PREVENT INJURIES:

Stop the motor.

Apply parking brakes.

Remove the ignition key.

Disconnect the wire from the spark plug(s) and keep away from spark plug(s) to prevent accidental starting.

Install the double pulley support as shown on the male hitch by using two 5/16 x 1" bolts (item 1) and flange nuts. Tighten the bolts firmly.

9

CAUTION

9

TO PREVENT INJURIES:

Always raise the attachment to reduce the tension on the spring before applying or releasing tension on the helper spring. Firmly hold the handle when you release the tension because the arm will kick back due to the tension on the spring.

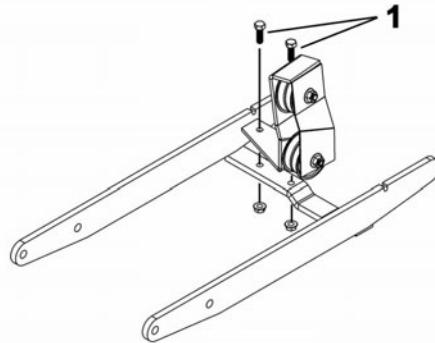

Install pulley support

Install the snowblower to the subframe as shown.

Make sure the snowblower is pushed in until locked into place by the springs (item 1).

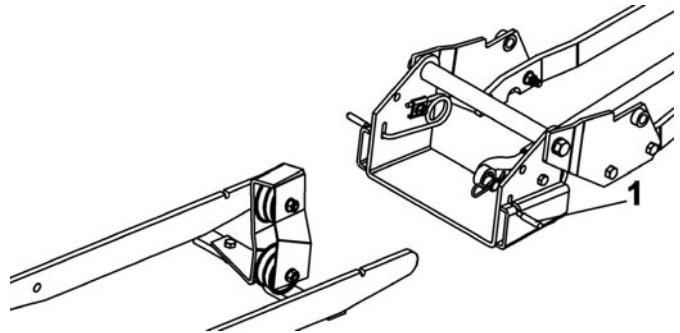

Install the snowblower

Insert the handle (item 1) into the support (item 2) as shown.

Install the hook (item 3) on the rotation worm (item 4). Insert the hook in the handle (item 1) and secure with a 2.5 mm hair pin (item 5).

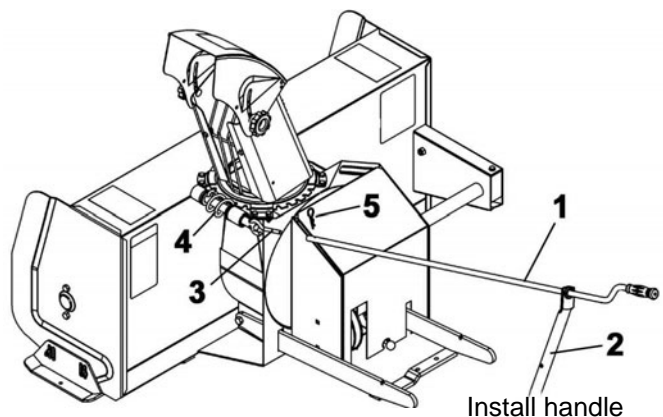

Install handle

ASSEMBLY

9

CAUTION

9

Never use the snowblower without the belt guard.

Remove the belt guard from the back of snowblower.

Move the tension arm (item 5) towards the back to facilitate installation.

Install the belt on the snowblower by inserting it between the two flat pulleys (item 1) and around the snowblower pulley (item 2).

Install the belt under the tractor as shown and make sure the bottom strand (item 3) between the snowblower pulley and the left hand side pulley is not twisted.

NOTE: Do not hook the helper spring (item 4) to the lift lever (item 9) right now. The belt must be adjusted before installing the spring.

Apply tension on the belt by moving the tension arm (item 5) towards the front

Check the tension on the belt and adjust if necessary. See maintenance section for adjustment instructions.

Raise the snowblower in order to install the helper spring.

Move the tension arm (item 5) towards the back.

Hook the helper spring (item 4) in the eyelet (item 6) that is welded to the lift lever (item 9).

Apply tension on the belt by moving the tension arm towards the front.

Secure in the hole (item 8) with a 3 mm hair pin (item 7).

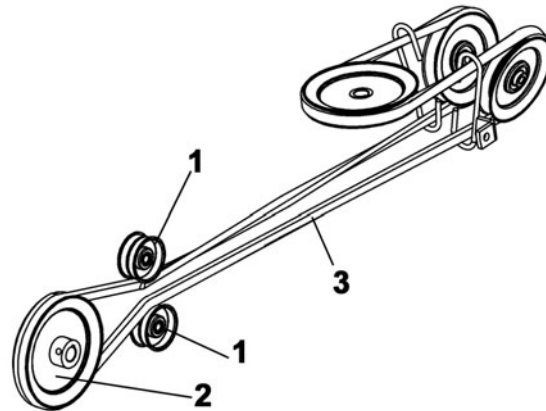

Install belt

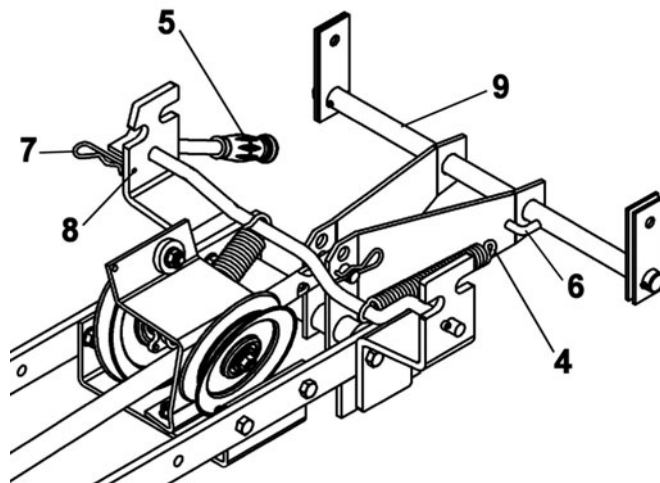

Install helper spring

9

CAUTION

9

TO PREVENT INJURIES:

Always raise the attachment to reduce the tension on the spring before applying or releasing tension on the helper spring. Firmly hold the handle when you release the tension because the arm will kick back due to the tension on the spring.

ASSEMBLY

VERIFY BELT ROUTING:

- Lower the snowblower to the ground and let it run for a few seconds under supervision.
- Disengage the snowblower and stop the engine.
- Check the belt to make sure it is well inserted in the pulleys and that it has not flipped on its side in the pulleys and that it does not touch the belt guides.
- Reinstall the belt guard.

VERIFY SKID SHOE ADJUSTMENT:

LEVEL PAVED SURFACE: Adjust skid shoes to allow 3/16 to 1/4" clearance (A) between cutting edge and surface.

UNEVEN OR GRAVEL SURFACE: Adjust skid shoes to allow 1/2 to 5/8" clearance (A) between cutting edge and surface.

VERIFY TIRE PRESSURE:

Attachments should raise 3" to 4" above ground (no more, no less) if not check and adjust tractor tire pressure as follows:

Front tires:	20-25 psi
Back tires:	8-10 psi

Tire pressure must be even on both sides of the tractor.

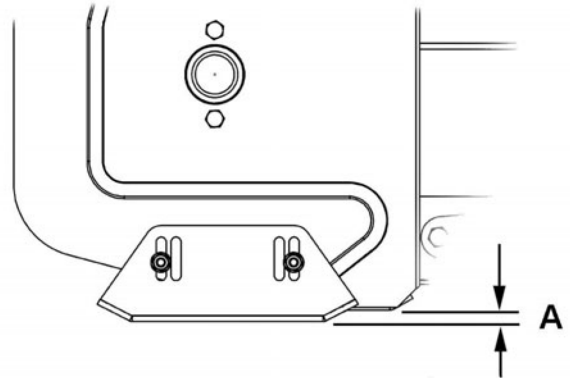

Adjust skid shoes

ASSEMBLY

ROTARY BROOM INSTALLATION:

Refer to Rotary Broom owner's manual, parts breakdown section for parts identification.

9 WARNING 9

FOR YOUR SECURITY:

Read the Rotary Broom owner's manual for safety precautions and rules.

Follow the assembly and operation instructions.

9 WARNING 9

TO PREVENT INJURIES:

Stop the motor.

Apply parking brakes.

Remove the ignition key.

Disconnect the wire from the spark plug(s) and keep away from spark plug(s) to prevent accidental starting.

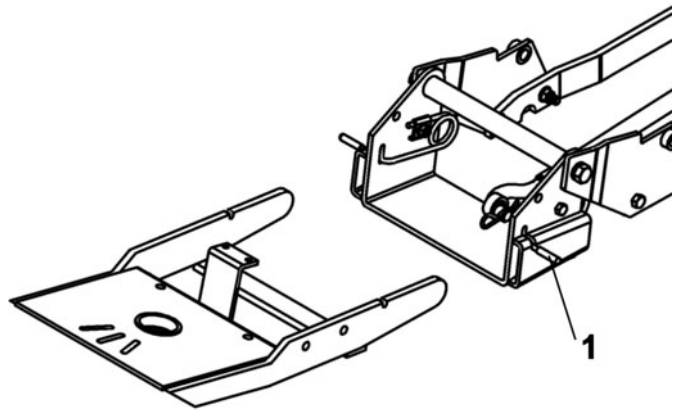

Install the rotary broom to the subframe as shown.

Make sure the rotary broom is pushed in until locked into place by the springs (item 1).

Install the rotary broom

Insert the handle (item 1) into the support (item 2) as shown.

Install the handle (item 1) on the control rod (item 3) as shown and secure with a 2.5 mm hair pin.

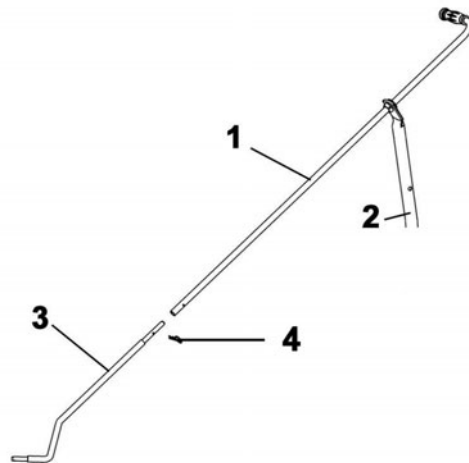

Install the handle

ASSEMBLY

9

CAUTION

9

Never use the Rotary Broom without the belt guard.

Install the belt as shown

NOTE: Do not hook the helper spring (item 4) to the lift lever (item 9) right now. The belt must be adjusted before installing the spring.

Apply tension on the belt by moving the tension arm (item 5) towards the front.

Check the tension on the belt and adjust if necessary. See maintenance section for adjustment instructions.

Raise the rotary broom in order to install the helper spring.

Move the tension arm (item 5) towards the back.

Hook the helper spring (item 4) in the eyelet (item 6) that is welded to the lift lever (item 9).

Apply tension by moving the tension arm towards the front and secure in the hole (item 8) with a 3 mm hair pin (item 7).

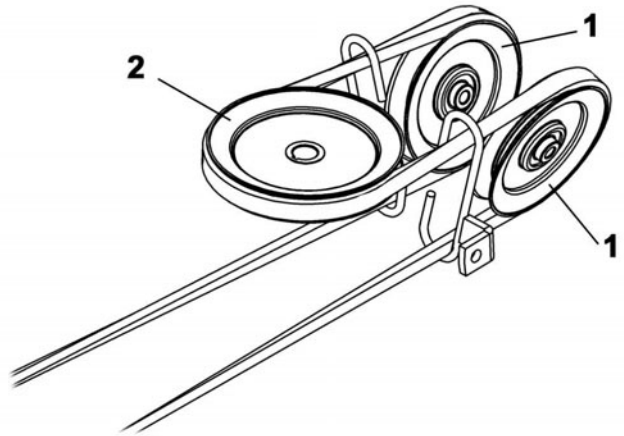

Install the belt

9

CAUTION

9

TO PREVENT INJURIES:
Always raise the attachment to reduce the tension on the spring before applying or releasing tension on the helper spring. Firmly hold the handle when you release the tension because the arm will kick back due to the tension on the spring.

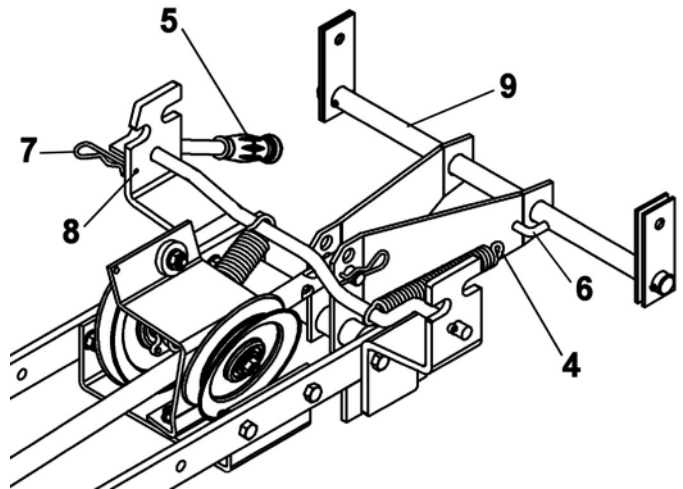

Install the spring

ASSEMBLY

VERIFY BELT ROUTING:

- Lower the rotary broom to the ground and let it run for a few seconds under supervision.
- Disengage the rotary broom and stop the engine.
- Check the belt to make sure it is well inserted in the pulleys and that it has not flipped on its side on the pulleys and that it does not touch the belt guides.
- Reinstall the belt guard.

VERIFY TIRE PRESSURE:

Attachments should raise 3" to 4" above the ground (no more, no less) if not, check and adjust tractor tire pressure as follows:

Front tires:	20-25 psi
Back tires:	8-10 psi

Tire pressure must be even on both sides of the tractor.

ASSEMBLY

UTILITY BLADE INSTALLATION:

Refer to Utility Blade owner's manual, parts breakdown section for parts identification.

9 WARNING 9

FOR YOUR SECURITY:

Read the Utility Blade owner's manual for safety precautions and rules.
Follow the assembly and operation instructions.

9 WARNING 9

TO PREVENT INJURIES:

Stop the motor.
Apply parking brakes.
Remove the ignition key.
Disconnect the wire from the spark plug(s) and keep away from spark plug(s) to prevent accidental starting.

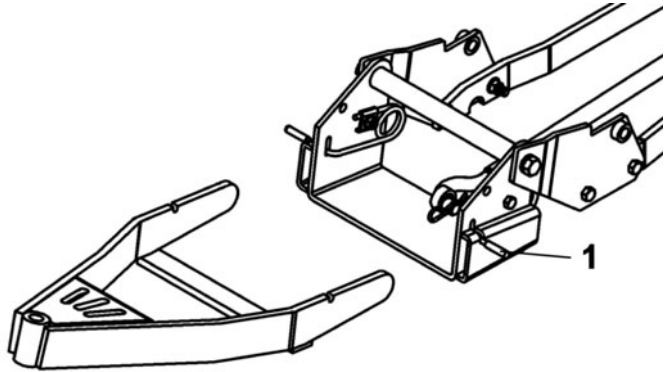

Install the utility blade to the subframe as shown.

Make sure the blade is pushed in until locked into place by the springs (item 1).

Note: If the utility blade does not scrape enough, remove the helper spring.

Install utility blade

Insert the handle (item 1) into the support (item 2) as shown.

Install the handle (item 1) on the control rod (item 3) as shown and secure with a 2.5 mm hair pin.

9 CAUTION 9

TO PREVENT INJURIES:

Always raise the attachment to reduce the tension on the spring before applying or releasing tension on the helper spring. Firmly hold the handle when you release the tension because the arm will kick back due to the tension on the spring.

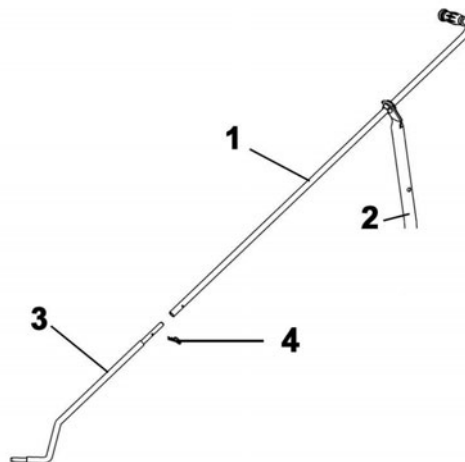

VERIFY TIRE PRESSURE:

Attachments should raise 3" to 4" above the ground (no more, no less) if not, check and adjust tractor tire pressure as follows:

Front tires: 20-25 psi
Back tires: 8-10 psi

Tire pressure must be even on both sides of the tractor.

Install handle

MAINTENANCE & DISMOUNTING

9

WARNING

9

TO PREVENT INJURIES:

Stop the motor.

Apply parking brakes.

Remove the ignition key.

Disconnect the wire from the spark plug(s) and keep away from spark plug(s) to prevent accidental starting.

MAINTENANCE

- a) Check mounting bolts at frequent intervals for proper tightness to be sure the equipment is in safe working condition.
- b) Apply oil at all pivot points.

BELT ADJUSTMENT

When the attachment is on the ground, the tension arm should be vertical or at approximately 90° with the subframe's flat bars.

If it is not vertical, release the tension on the belt by moving the arm (item 1) towards the back. Adjust the tension on the belt by moving the left hand side adjustable pulley (item 3). To adjust, loosen the bolt located in the middle of the pulley and slide the pulley in the slot. Tighten the bolt. Apply tension on the belt by moving the tension arm towards the front. Verify the adjustment. Make sure the tension arm (item 2) is approximately at 90° with the subframe's flat bars and blocked in the hole with a 3 mm hair pin.

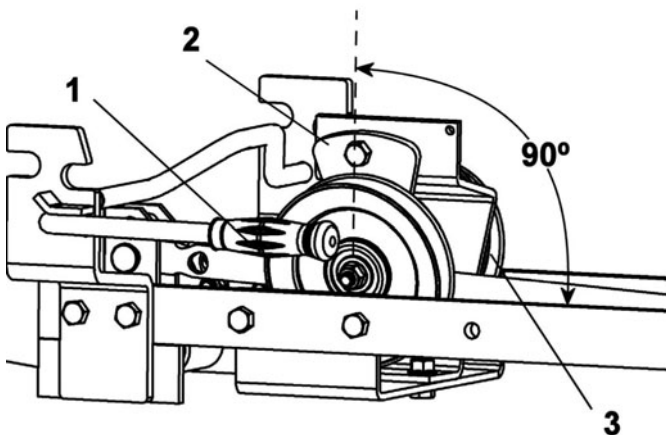

SUBFRAME DISMOUNTING

See Attachment Owner's manual (Snowblower, Rotary Broom, Utility Blade) for attachment dismounting instructions.

- a) Remove the rear counterweight.
- b) Release tension on the belt by moving the tension arm towards the back.

9

CAUTION

9

TO PREVENT INJURIES:

Always raise the attachment to reduce the tension on the spring before applying or releasing tension on the helper spring. Firmly hold the handle when you release the tension because the arm will kick back due to the tension on the spring.

- c) Unhook the spring
- d) Remove the two pins that hold the back of the subframe.
- e) Remove the two pins that hold the front of the subframe.
- f) Unhook and lower carefully the subframe.
- g) Carefully pull out the subframe by middle of the tractor from the left side between the front and rear wheels.

END OF SEASON STORAGE

- a) Clean and repaint all parts from which the paint has worn.
- b) Apply oil at all pivot points.
- c) Inspect and replace all defective parts before next season.

TORQUE SPECIFICATION TABLE

GENERAL TORQUE SPECIFICATION TABLE USE THE FOLLOWING TORQUES WHEN SPECIAL TORQUES ARE NOT GIVEN

NOTE: These values apply to fasteners as received from supplier, dry or when lubricated with normal oil. They do not apply if special graphited or moly disulphide greases or other extreme pressure lubricants are used. This applies to both UNF and UNC threads.

SEE Grade No.		2				5				8 *			
BOLT HEAD IDENTIFICATION MARKS AS PER GRADE NOTE MANUFACTURING MARKS WILL VARY		TORQUE				TORQUE				TORQUE			
BOLT SIZE		POUNDS FEET		NEWTON-METERS		POUNDS FEET		NEWTON-METERS		POUNDS FEET		NEWTON-METERS	
Inches	Millimetre	Min.	Max.	Min.	Max.	Min.	Max.	Min.	Max.	Min.	Max.	Min.	Max.
1/4"	6.35	5	6	6.8	8.13	9	11	12.2	14.9	12	15	16.3	30.3
5/16"	7.94	10	12	13.6	16.3	17	20.5	23.1	27.8	24	29	32.5	39.3
3/8"	9.53	20	23	27.1	31.2	35	42	47.5	57	45	54	61	73.2
7/16"	11.11	30	35	40.7	47.4	54	64	73.2	86.8	70	84	94.9	113.9
1/2"	12.7	45	52	61	70.5	80	96	108.5	130.2	110	132	149.2	179
9/16"	14.29	65	75	88.1	101.6	110	132	149.2	179	160	192	217	260.4
5/8"	15.88	95	105	128.7	142.3	150	180	203.4	244.1	220	264	298.3	358
3/4"	19.05	150	185	203.3	250.7	270	324	366.1	439.3	380	456	515.3	618.3
7/8"	22.23	160	200	216.8	271	400	480	542.4	650.9	600	720	813.6	976.3
1"	25.4	250	300	338.8	406.5	580	696	786.5	943.8	900	1080	1220.4	1464.5

*Thick nuts must be used with grade 8 bolts

METRIC BOLT TORQUE SPECIFICATIONS							
Size Screw	Grade No.	Pitch (mm)	COARSE THREAD		FINE THREAD		
			Pounds Feet	Newton-Meters	Pitch (mm)	Pounds Feet	Newton-Meters
M6	4T	1.00	3.6 - 5.8	4.9 - 7.9	-	-	-
	7T		5.8 - 9.4	7.9 - 12.7		-	-
	8T		7.2 - 10	9.8 - 13.6		-	-
M8	4T	1.25	7.2 - 14	9.8 - 19	1.00	12 - 17	16.3 - 23
	7T		17 - 22	23 - 29.8		19 - 27	25.7 - 36.6
	8T		20 - 26	27.1 - 35.2		22 - 31	29.8 - 42
M10	4T	1.50	20 - 25	27.1 - 33.9	1.25	20 - 29	27.1 - 39.3
	7T		34 - 40	46.1 - 54.2		35 - 47	47.4 - 63.7
	8T		38 - 46	51.5 - 62.3		40 - 52	54.2 - 70.5
M12	4T	1.75	28 - 34	37.9 - 46.1	1.25	31 - 41	42 - 55.6
	7T		51 - 59	69.1 - 79.9		56 - 68	75.9 - 92.1
	8T		57 - 66	77.2 - 89.4		62 - 75	84 - 101.6
M14	4T	2.00	49 - 56	66.4 - 75.9	1.50	52 - 64	70.5 - 86.7
	7T		81 - 93	109.8 - 126		90 - 106	122 - 143.6
	8T		96 - 109	130.1 - 147.7		107 - 124	145 - 168
M16	4T	2.00	67 - 77	90.8 - 104.3	1.50	69 - 83	93.5 - 112.5
	7T		116 - 130	157.2 - 176.2		120 - 138	162.6 - 187
	8T		129 - 145	174.8 - 196.5		140 - 158	189.7 - 214.1
M18	4T	2.00	88 - 100	119.2 - 136	1.50	100 - 117	136 - 158.5
	7T		150 - 168	203.3 - 227.6		177 - 199	239.8 - 269.6
	8T		175 - 194	237.1 - 262.9		202 - 231	273.7 - 313
M20	4T	2.50	108 - 130	146.3 - 176.2	1.50	132 - 150	178.9 - 203.3
	7T		186 - 205	252 - 277.8		206 - 242	279.1 - 327.9
	8T		213 - 249	288.6 - 337.4		246 - 289	333.3 - 391.6

PARTS BREAKDOWN / NOMENCLATURE DES PIÈCES PUSH FRAME / CHÂSSIS DE POUSSÉE

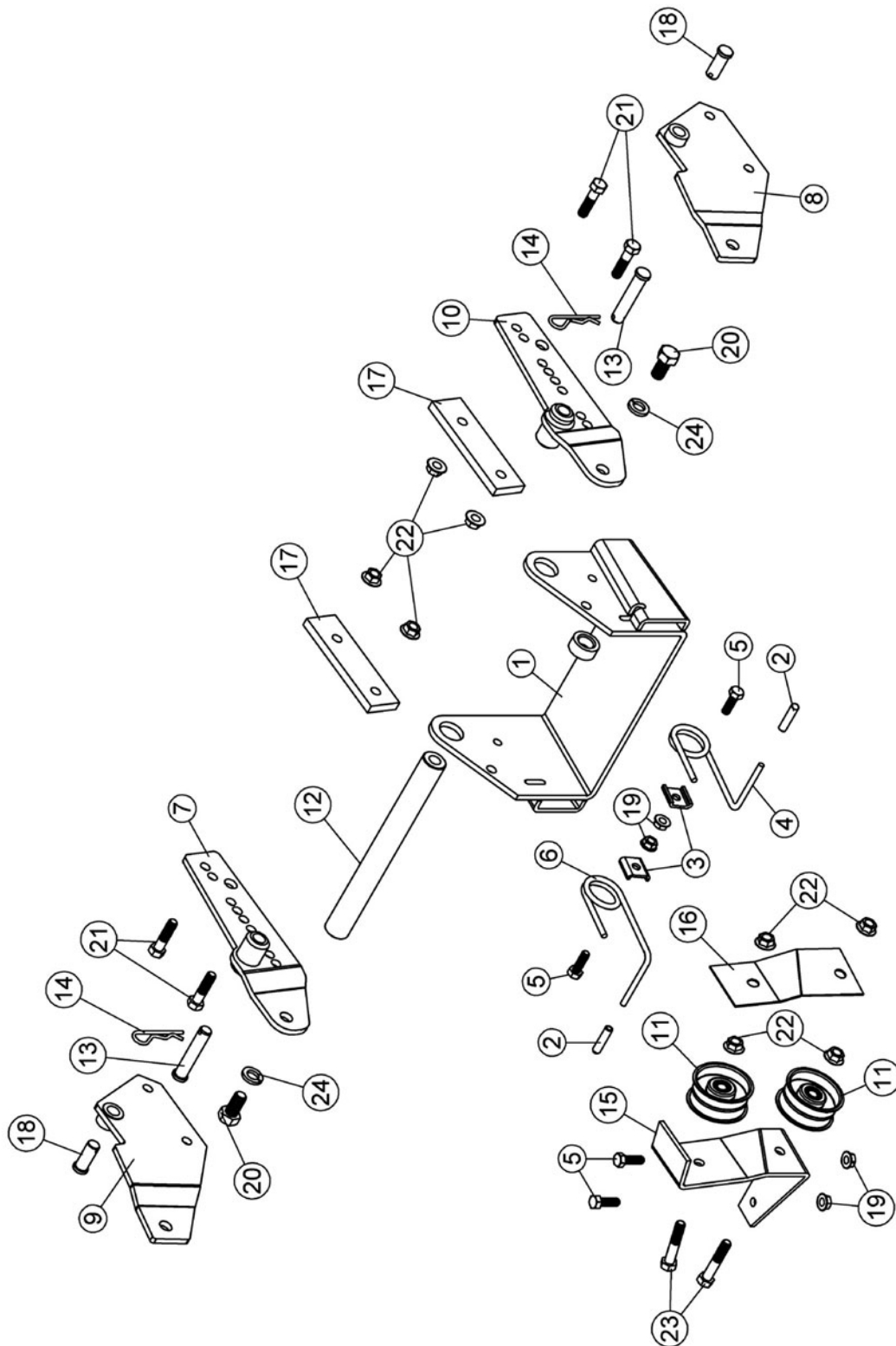

PARTS LIST / LISTE DES PIÈCES

Ref. Réf.	English description	Description française	Qty. Qté.	Part # Pièce #
1	Pivot support	Support de pivot	1	102655
2	Handgrip	Poignée	2	102248
3	Spring bracket	Fixation du ressort	2	102210
4	Spring lock left	Ressort de barrure gauche	1	102208
5	Hex. bolt 5/16" n.c. x 1"	Boulon hex. 5/16" n.c. x 1"	4	O/L
6	Spring lock right	Ressort de barrure droit	1	102209
7	Right front support	Support avant droit	1	103526
8	Left front support	Support avant gauche	1	103078
9	Right front support	Support avant droit	1	103079
10	Left front support	Support avant gauche	1	103525
11	Flat pulley	Poulie plate	2	102057
12	Pin	Goupille	1	102258
13	Pin 0.50" x 2.52"	Goupille 0.50" x 2.52"	2	102189
14	Hair pin 3 mm	Goupille à ressort 3 mm	2	102617
15	Double pulley support	Support de poulie double	1	103284
16	Idler guard	Garde-poulie	1	103285
17	Shim	Cales	2	102573
18	Pin 0.50" x 1.25"	Goupille 0.50" x 1.25"	2	103070
19	Flange nut 5/16" n.c.	Écrou à bride 5/16" n.c.	4	O/L
20	Hex. bolt 1/2" n.c. x 1"	Boulon hex. 1/2" n.c. x 1"	2	O/L
21	Hex. bolt 3/8" n.c. x 1 1/2"	Boulon hex. 3/8" n.c. 1 1/2"	4	O/L
22	Flange nut 3/8" n.c.	Écrou à bride 3/8" n.c.	8	O/L
23	Hex. bolt 3/8" n.c. x 2"	Boulon hex. 3/8" n.c. x 2"	2	O/L
24	Lock washer 1/2"	Rondelle de blocage 1/2"	2	O/L

O/L = Obtain locally/obtenir localement

PARTS BREAKDOWN / NOMENCLATURE DES PIÈCES SUBFRAME / SOUS-CHÂSSIS

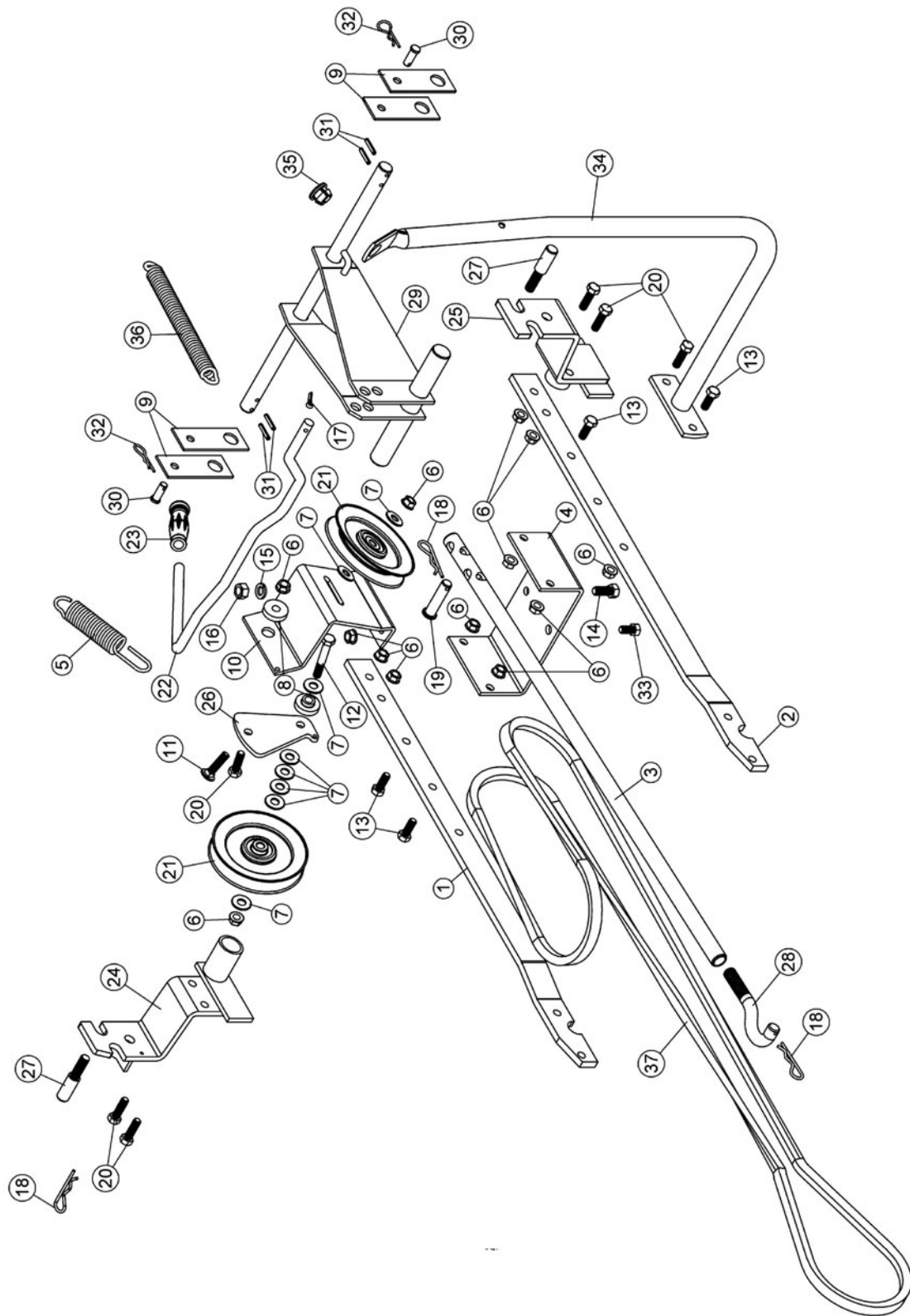

PARTS LIST / LISTE DES PIÈCES

Ref. Réf.	English description	Description française	Qty. Qté.	Part # Pièce #
1	Right subframe flat bar	Fer plat droit du sous-chassis	1	102263
2	Left subframe flat bar	Fer plat gauche du sous-chassis	1	102262
3	Push tube	Tube de poussée	1	103076
4	Support plate	Plaque de support	1	102070
5	Spring 1 1/8"	Ressort 1 1/8"	1	102004
6	Flange nut 3/8" n.c.	Écrou à bride 3/8" n.c.	13	O/L
7	Flat washer 7/16" hole	Rondelle plate 7/16" trou	8	O/L
8	Flange washer	Rondelle à bride	2	102081
9	Link	Lien	4	103072
10	Pulley support	Support de poulie	1	102082
11	Carriage bolt 3/8" n.c. x 1-1/2"	Boulon à carrosserie 3/8" n.c. x 1 1/2"	1	O/L
12	Hex. bolt 3/8" n.c. x 2 1/2"	Boulon hex 3/8" n.c. x 2 1/2"	1	O/L
13	Hex. bolt 3/8" n.c. x 1"	Boulon hex. 3/8" n.c. x 1"	4	O/L
14	Hex. bolt 7/16" n.c. x 1"	Boulon hex. 7/16" n.c. x 1"	1	O/L
15	Lock washer 7/16"	Rondelle de blocage 7/16"	1	O/L
16	Hex. nut 7/16" n.c.	Écrou hex. 7/16" n.c.	1	O/L
17	Cotter pin 5/32" x 1"	Goupille fendue 5/32" x 1"	1	O/L
18	Hair pin 3 mm	Goupille à ressort 3 mm	3	102617
19	Pin 0.53" x 2.13"	Goupille 0.53" x 2.13"	1	102079
20	Hex. bolt 3/8" n.c. x 1 1/4"	Boulon hex. 3/8" n.c. x 1 1/4"	6	O/L
21	V Pulley	Poulie en "V"	2	102086
22	Idler arm	Bras de tension	1	103074
23	Hand grip	Poignée	1	102062
24	Right rear support	Support arrière droit	1	103081
25	Left rear support	Support arrière gauche	1	103082
26	Idler arm	Bras de poulie	1	102089
27	Mounting pin	Goupille de montage	2	102257
28	Adjusting rod	Tige d'ajustement	1	102653
29	Lift lever	Levier de relevage	1	103075

O/L = Obtain locally/obtenir localement

PARTS LIST / LISTE DES PIÈCES

Ref. Réf.	English description	Description française	Qty. Qté.	Part # Pièce #
30	Pin 0.38" x 1.00"	Goupille 0.38" x 1.00"	2	103077
31	Roll pin 3/16" x 1"	Goupille roulée 3/16" x 1"	4	O/L
32	Hair pin 2.5 mm	Goupille à ressort 2.5 mm	2	102013
33	Hex. bolt 3/8" n.c. x 3/4"	Boulon hex. 3/8" n.c. x 3/4"	1	O/L
34	Handle support	Support de manivelle	1	102243
35	Plastic grommet	Oeillet de plastique	1	102063
36	Spring	Ressort	1	103073
37	V-Belt, B-120	Courroie en V, B-120	1	102048

O/L = Obtain locally/obtenir localement

ATTACHMENTS

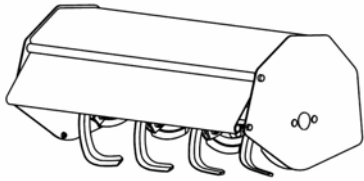

ROTARY TILLER #700312

Mounts to the rear of lawn & garden tractors 14 to 25 HP. Comes complete with drive & manual lift mechanisms & mounting hardware.

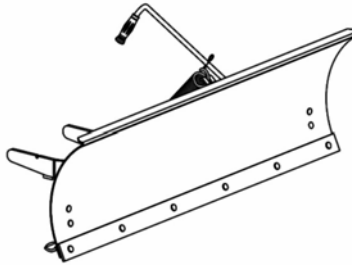

UTILITY BLADE #700266

Mounts on the same subframe as the snowblower & rotary broom.

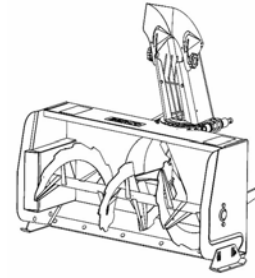

SNOWBLOWER

#700210 40"
#700211 44"
#700255 40"
#700300 48"

Fits on same subframe as rotary broom and utility blade.

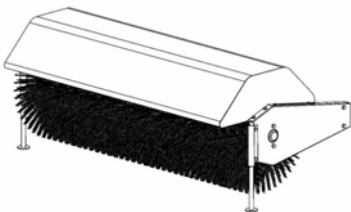

ROTARY BROOM

#700286 with nylon brush
/#700316 with polypropylene brush.

Fits on same subframe as snowblower & utility blade. Requires an adaptor.

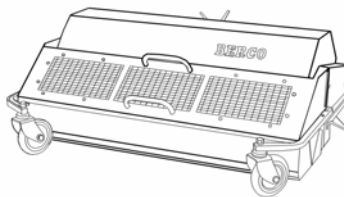

DEBRIS COLLECTOR #700235

Quickly & easily fitted on front of rotary brooms #700286 and #700316. Collects debris in container with easy manual dumping. Reduces dust.

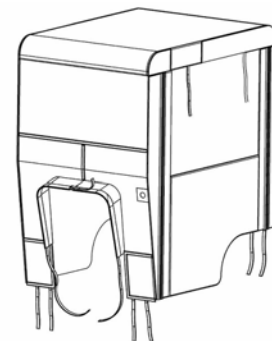

TRACTOR WINTER CAB #700271

Universal type fits on a wide variety of lawn and garden tractors.

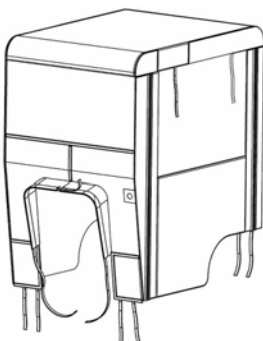

TRACTOR SCREEN CAB #700313

Universal type fits on a wide variety of lawn and garden tractors.

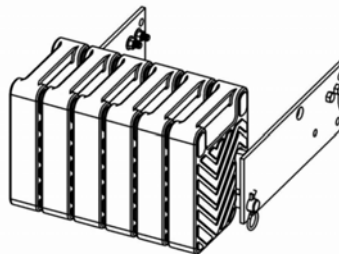

COUNTERWEIGHT

#700240 Universal rear weights
#700246 Rear weights Electrolux
Required for safety and traction. Counterbalances weight of attachment.

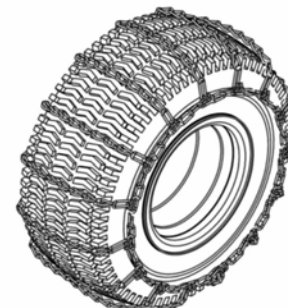

TIRE CHAINS

Two link spacing. Required for traction and safety.
Pkg. of 2