

OPERATION



WARNING



Read the vehicle owner's manual carefully. Be thoroughly familiar with the controls & proper use of the attachment. Know how to stop the accessory quickly.



WARNING



TO PREVENT INJURIES AND FOR MORE TRACTION WHEN USING AN ACCESSORY ON A VEHICLE:

- Do not drive faster than 3 km/hr (2 m/hr) with rotary broom on the ground.
- Do not drive faster than 10 km/hr (6 m/hr) with the rotary broom in raised position.
- Do not operate on a slope greater than 10°.
- Manufacturer approved tire chains are required (winter or slippery surfaces).
- Wearing ear muff, security glasses and a dust mask is recommended.



WARNING



When starting the engine on the accessory, make sure:

- The indicator light is turned on to signal that the disengagement is completely finished.
- The vehicle's hand brake is activated.
- To lift the accessory off the ground.

FAMILIARISATION OF THE CONTROLS:

Familiarize yourself with the controls before using.

- a) Raise the broom.
- b) Disengage the broom (if applicable).
- c) Pull the emergency switch.
- d) Start the engine (full throttle).
- e) Engage the broom.
- f) Lower to the ground.
- g) Adjust the pressure on the brush with the adjustment handle (item 1).

RAISING AND LOWERING THE ROTARY BROOM:

Use the winch switch control to raise and lower the rotary broom.

ANGLE ADJUSTMENT:

In order to avoid causing damage to the mechanism:

- a) Raise the broom.
- b) Activate the control to turn the broom to the angle desired.
- c) Lower the broom to the ground.

PRESSURE ADJUSTMENT ON THE BRUSH



WARNING



PREVENT INJURIES

Be careful of the danger zone when starting the engine or adjusting the pressure on the brush.

- Stop the vehicle.
- Activate the parking brake.

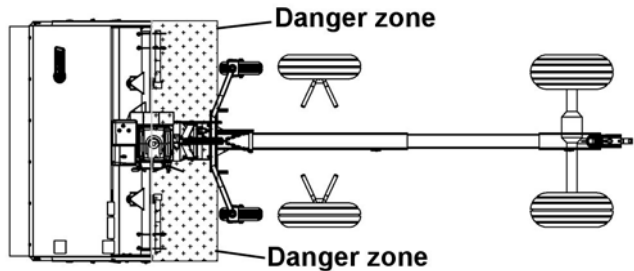

By turning the adjustment handle (item 1) counter clockwise, the pressure of the brush on the ground increases. By turning the adjusting handle clockwise, the pressure of the brush on the ground decreases.

IMPORTANT: Adjust frequently to compensate for brush wear. Remember to sweep with the tips of the bristles like a broom and not with the sides of the bristles like a mop. Too much pressure can decrease the brush life up to 95%.

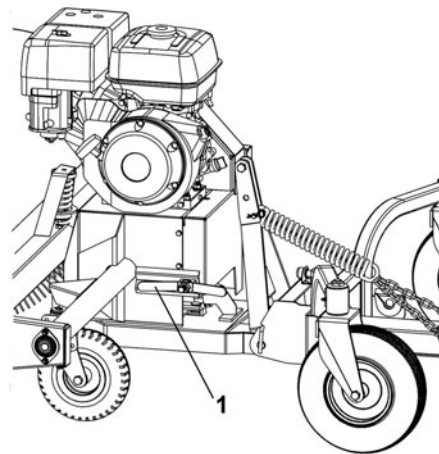

Adjust the pressure on the brush

Never sweep with the sides of bristles!

Sweep with the tips!
Do not mop!

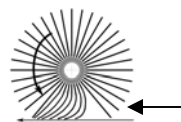

Too much pressure=
Shortens brush life!

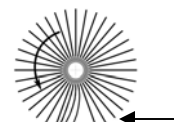

Flick action

←
Road surface