

MAINTENANCE

REPLACING THE TINES



WARNING



TO PREVENT INJURIES:

Stop the motor.
Apply parking brake.
Remove the ignition key.
Disconnect the wire from the spark plug(s) and keep away from spark plug(s) to prevent accidental starting.

- Park the vehicle safely.
- Raise the rotary tiller as high as it will go and put some blocks under the rotary tiller.

Note: Each group of tines must have two left tines and two right tines.

For reference purposes:

- Alternate left and right tines in each group.
- A bolt with **no spacer** is 3/8 x 1 1/4" long.
- A bolt with **one spacer** is 3/8 x 1 3/4" long.
- A bolt with **two spacers** is 3/8 x 2 1/4" long.

LEFT GROUP OF TINES:

Remove the nuts (item 1), bolts (item 2) spacers (item 3), two left tines (4) and two right tines (item 5).
Install the new tines with same hardware in exactly the same position as the old ones were installed.

MIDDLE GROUP OF TINES:

Remove the nuts (item 6), bolts (item 7), spacers (item 8), two left tines (item 9) and two right tines (item 10).
Install the new tines with same hardware in exactly the same position as the old ones were installed.

RIGHT GROUP OF TINES:

Remove the nuts (item 11), bolts (item 12) spacers (item 13), two left tines (item 14) and two right tines (item 15).
Install the new tines with same hardware in exactly the same position as the old ones were installed.



CAUTION



TO PREVENT INJURIES:

Always safely block the tiller if you have to work under it. It is not recommended to work under the tiller because it could fall on you and cause very serious injuries.

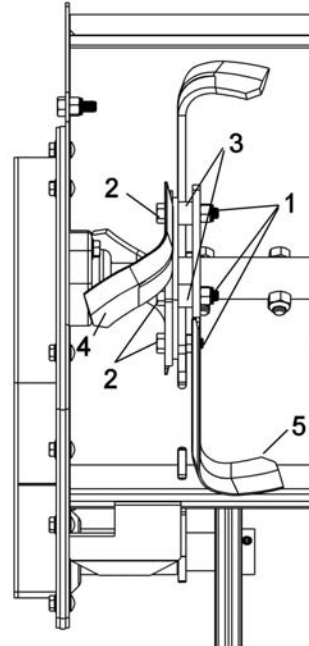

Left group of tines

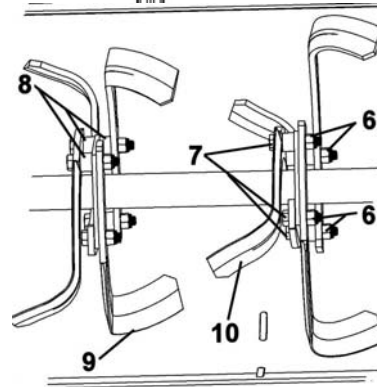

Middle group of tines

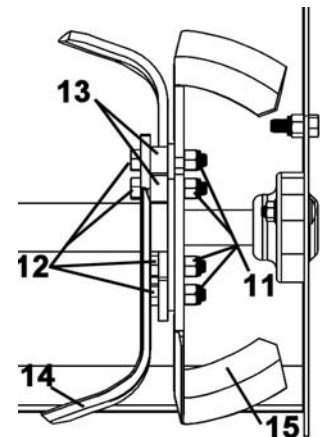

Right group of tines