

MAINTENANCE & DISMOUNTING



WARNING



TO PREVENT INJURIES:

Stop the snowblower motor.
Apply parking brakes.
Remove the ignition key.
Disconnect the wire from the spark plug(s) and keep away from spark plug(s) to prevent accidental starting.

MAINTENANCE

- Check mounting bolts at frequent intervals for proper tightness in order to prevent costly repairs. Make sure your snowblower is in safe working condition.
- Provide adequate blocking before working under the snowblower when in raised position.

ADJUSTMENTS

SKID SHOE ADJUSTMENT:

Level Paved Surface: Adjust skid shoes to allow 3/16" to 1/4" clearance between cutting edge and surface.

Uneven or Gravel Surface: Adjust skid shoes to allow 1/2" to 5/8" clearance between cutting edge and surface.

LUBRICATION

Grease the fork pivots and the hub on the wheels after every 4 hours of use.

Apply oil at all pivot points.

Drive Chains: Lubricate with chain saw chain lubricant every four hours of operation and at the end of each operation.

Chute Rotation System: Oil chute base, rotation worm every eight hours of operation.

CUTTING EDGE MAINTENANCE

Verify from time to time the wearing on the cutting edge to make sure you do not wear out the base of the snowblower's chasis. This cutting edge is reversible. Unscrew the bolts and turn the cutting edge, reinstall and tighten the bolts securely.

AUGER AND FAN SHEAR BOLT REPLACEMENT

The shear bolts are to be considered a preventive measure and not an assured protection. Operator vigilance is required. Thoroughly inspect the areas where the snowblower is to be used and remove all foreign objects.

SNOWBLOWER PULLEY REPLACEMENT or ALIGNMENT:

Clean the parts before aligning or replacing the pulley. Apply some "Lock Tite" 2760 on the key and the set screws. Tighten firmly.

To avoid damage to the snowblower:

Use only the original shear bolts (grooved bolts).

#104000 in bags of 10 for the augers.

#103999 in bags of 10 for the fan.

The use of any other shear bolt will not insure any protection and may void the warranty.

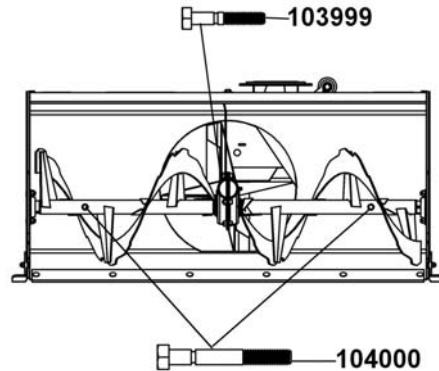

DISMOUNTING

- Select a level surface, set parking brake, stop the engine, and remove the ignition key to prevent accidental starting.
- Lower the accessory to the ground
- Unhook the turnbuckles from the front of the vehicle, (Tip: slacken one of the turnbuckles in order to keep the adjustment), the hook from the winch and the hitch from the rear of the vehicle.
- Remove the control box (item 1) from the support (item 2). Disconnect the wires (item 3) and place the box on the accessory.
- Remove the vehicle.

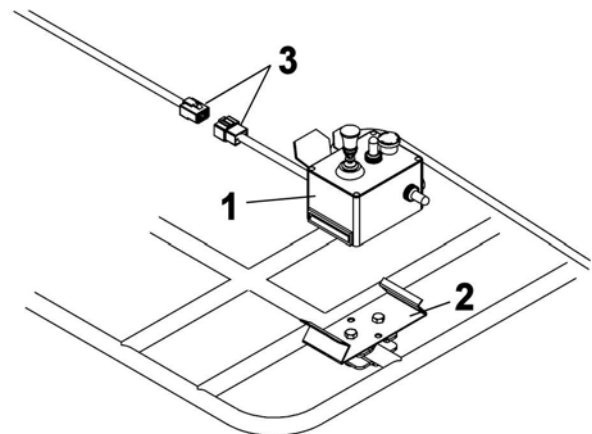

STORAGE

- Clean snowblower and subframe thoroughly and repaint all parts from which paint has worn.
- List the replacement parts that will be needed to be replaced before the next season.
- Follow the instructions in the Lubrication section.
- Concerning the snowblower engine, follow the instructions in the engine owner's manual.
- Store the snowblower and the subframe in a dry place.