

# MAINTENANCE & DISMOUNTING

**BEFORE DOING ANY MAINTENANCE OR DISMOUNTING AN ACCESSORY, REFER TO THE SAFETY PRECAUTIONS.**

## **MAINTENANCE**

- a) Check oil level in gear box every fifty hours and fill to plug level with SAE-90-EP oil when necessary.
- b) Grease the wheel axles after every eight hours of use.
- c) Chain: do not lubricate when used in dusty conditions. After use, wash clean and lubricate.
- d) Adjust the chain frequently by moving the idler sprocket to give 1/2" deflection.
- e) Frequently clean the interior and exterior of hood, dirt, mud, ice, etc, accumulation adds weight on the brush and could result in premature wear of brush.
- f) Check mounting bolts at frequent intervals for proper tightness to be sure equipment is in safe working conditions.
- g) Apply oil at all pivot points.
- h) Inspect the air filter on the vehicle and accessory every day. Clean it or replace it when necessary. Change the oil more often when working in dusty conditions. See the owner's manual for the vehicle or for the accessory.



## **CAUTION**



**Never use the Rotary Broom without the belt guard.**

## **BELT REPLACEMENT:**

For belt part numbers, refer to parts breakdown section for parts identification.

- a) Remove the belt guard (item 1).
- b) Replace the belt (item 2).
- c) Engage the accessory.
- d) Make sure the pulleys are well aligned.
- e) Engage and reinstall the belt guard.

## **BRUSH REPLACEMENT:**

See parts breakdown section for parts identification.

- a) Remove the hood.
- b) Loosen the chain idler sprocket.
- c) Remove the bolts from both flangettes that holds the brush hollow shaft.
- d) Remove the brush hollow shaft from the broom frame.
- e) Loosen the set screw and remove the right bearing from the brush hollow shaft
- f) Remove the bolt which retains the brush to the brush hollow shaft.
- g) Remove the brush tube from axle.
- h) Install the new brush by reversing the procedure.
- i) Adjust the tension on the chain by moving the idler sprocket to give a 1/2" deflection on the length of the chain.

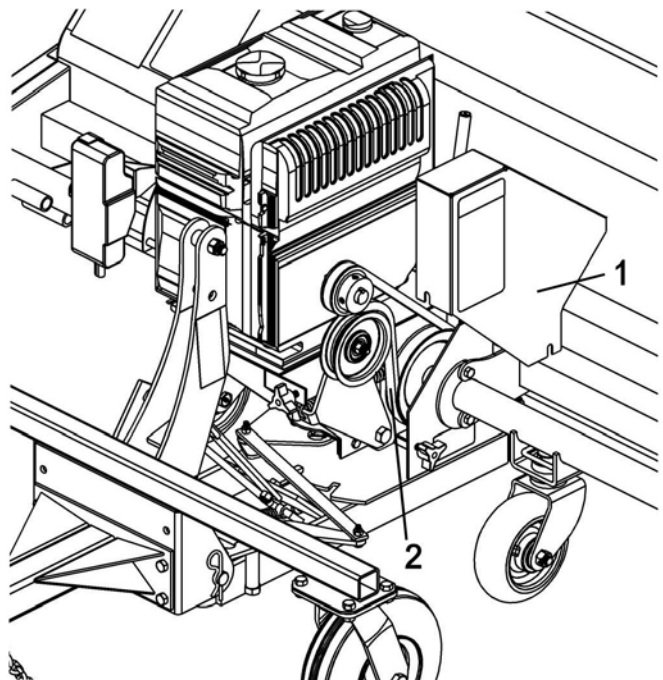

# MAINTENANCE & DISMOUNTING

## DISMOUNTING

- a) Select a level surface, set parking brake, stop the engine, and remove the ignition key to prevent accidental starting.
- b) Straighten the broom perpendicular with the vehicle.
- c) Set the parking stands in their most extended position Make sure the brush bristles never touch the ground.
- d) Lower the broom to the ground.
- e) Unhook the turnbuckles from the front of the vehicle, the hook from the winch and the hitch from the rear of the vehicle.
- f) Remove the control box (item 1) from the support (item 2). Disconnect the wires (item 3) and place the box on the accessory.
- g) Remove the vehicle.

## END OF SEASON STORAGE

- a) Clean the broom and inside of the hood and paint all the parts where the paint has worn off.
- b) Take note of the replacement parts needed for next season.
- c) Lubricate all grease fittings and all moving parts.
- d) Store broom on parking stands. Make sure the brush bristles never touch the ground.
- e) If brush bristles are exposed to direct sunlight, protect the bristles with a tarp.
- f) Store the broom in a dry place.

