

# OPERATION



## WARNING



**BEFORE MAKING ANY ADJUSTMENTS:**  
Stop the motor.  
Apply parking brakes.  
Remove the ignition key.  
Disconnect the wire from the spark plug(s) and keep away from spark plug(s) to prevent accidental starting.

### ROTARY BROOM ANGLE ADJUSTMENT

By turning the handle counter clockwise you unlock the latch and by pulling or pushing, you set the angle 0° to 20° on each side.

### PRESSURE ON THE BRUSH ADJUSTMENT

By turning the adjustment screw (item 1) counter clockwise, the gauge (item 3) moves higher and the pressure of the brush on the ground increases. By turning the adjusting screw clockwise, the gauge moves lower on the gear box frame (item 2) and the pressure of the brush on the ground decreases.

**IMPORTANT:** Maintain the gauge (item 3) even with the top of the gear box frame (item 2) or lower for general hard surface sweeping. Adjust frequently to compensate for brush wear. Remember to sweep with the tips of the bristles like a broom and not with the sides of the bristles like a mop. Too much pressure can decrease the brush life up to 95%.

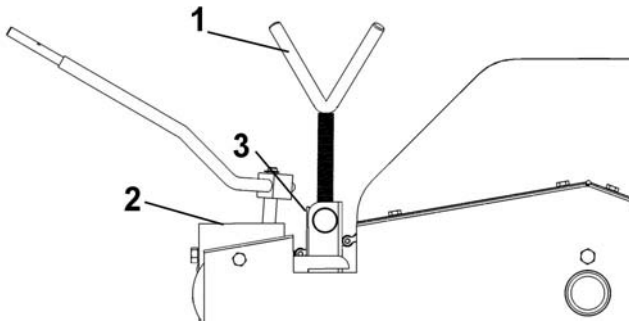

Adjust the pressure on the brush



## WARNING



**TO PREVENT INJURIES AND FOR MORE TRACTION WHEN USING AN ACCESSORY:**

- Rear counterweights of 100 lbs. minimum are required to counter-balance accessory's weight.
- Tractor manufacturer approved tire chains are required.
- Do not operate on slopes greater than 10°.
- When dismantling an attachment remove rear counterweights.

### GENERAL SWEEPING

Minimize dust by reducing brush speed and by sweeping after rain or on a day with high moisture.

### SNOW SWEEPING

Adjust the gauge (item 3) to be even with the top of gear box frame. The broom works well for light snow removal.

Sweep with the wind blowing in the direction of broom discharge.

**NOTE:** Foreign objects in the snow may be thrown faster than the snow itself.

Frequently clean the snow and ice accumulation from the top and bottom of the broom hood.

### LAWN DETHATCHING AND LEAF RAKING:

Lower the broom on a hard surface and lift the brush 1" from the ground by turning the adjusting screw clockwise. The brush is supported by dolly wheels. This adjustment is normally satisfactory but you may raise or lower depending upon grass height.

Low brush speed and ground speed is best for lawn dethatching and leaf raking.

Never sweep with the sides of bristles!

Sweep with the tips!  
Do not mop!

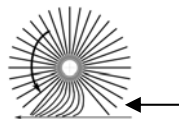

Too much pressure=  
Shortens brush life!

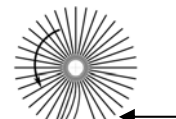

Flick action

Road surface